



# iWeld® Benchtop 993 Series

Setup Guide, Operation  
& Maintenance Manual



HARNESSING THE POWER OF HOT LIGHT™

**If you have additional questions about your machine or would like to provide feedback, a testimonial or present your applications results, please reach out — we'd love to hear from you!**

<b>LaserStar Technologies: Important Contacts</b>		
<b>Sales &amp; Training</b>	<b>Service &amp; Support</b>	<b>Corporate Office</b>
(407) 248-1142 <a href="mailto:sales@laserstar.net">sales@laserstar.net</a>	1-888-578-7782 <a href="mailto:service@laserstar.net">service@laserstar.net</a>	2461 Orlando Central Pkwy. Orlando, Florida 32809, USA





# Declaration of Conformity

Manufacturer Name: LaserStar Technologies Corporation®  
Manufacturer Address: 2461 Orlando Central Parkway  
Orlando, Florida 32809  
Phone / Fax: PH: (407) 248-1142 FX: (866) 708-5274  
Designation: iWeld® Benchtop Welding Workstation  
Model Number(s): 5xx-9xx-xx  
Year of Manufacture: 2026  
EC Directive(s): 2014 / 35 / EU (Low Voltage Directive)  
2014 / 30 / EU (EMC Directive)

## Standard(s) to which Conformity is Declared:

IEC 60825-1: 2014 Ed. 3.0  
IEC 61010-1: 2010 Ed. 3.0  
IEC 61000-6-2: 2006  
IEC 61000-6-4: 2007  
Listing: ETL Mark; Control Number: 5009261

This declaration is issued under the sole responsibility of LaserStar Technologies Corporation®. The object of this declaration is in conformity with relevant Union harmonization legislation.

I, the undersigned, hereby declare that the equipment specified above conforms to the above identified standards and fulfills the provisions of the EU directive(s).

A handwritten signature in black ink, appearing to read "James E. Gervais", written over a horizontal line.

**James E. Gervais**  
President and Chief Operating Officer

Date: January 04, 2026



# Declaration of Compliance

United States

Manufacturer Name: LaserStar Technologies Corporation®  
Manufacturer Address: 2461 Orlando Central Parkway  
Orlando, Florida 32809  
Phone / Fax: PH: (407) 248-1142 FX: (866) 708-5274  
Designation: iWeld® Benchtop Welding Workstation  
Model Number(s): 5xx-9xx-xx  
Year of Manufacture: 2026

## Standard(s) to which Compliance is Declared:

Code of Federal Regulations (CFR), Title 21; Part 1040.10, 1040.11 for Laser Products  
FCC 47CFR; Part 15, Subpart B (2017): Unintentional Radiators Class A Verification

I, the undersigned, hereby declare that the equipment specified above conforms to the above identified standards, as described in the test record.

A handwritten signature in black ink, appearing to read "James E. Gervais", written over a horizontal line.

**James E. Gervais**  
President and Chief Operating Officer

Date: January 04, 2026

# UK Product Declaration of Conformity

LaserStar Technologies Corporation, hereby declare that the product described below:

**Product Name:** iWeld®, **Model Number:** 591-993 series, **Description:** Laser Welder, **Intended Use:** Micro welding of metals

is in compliance with the following UK regulations:

- Electrical Equipment (Safety) Regulations 2016
- Electromagnetic Compatibility Regulations 2016

The product meets the essential requirements of the following UK directives:

- Low Voltage Directive (LVD)
- Electromagnetic Compatibility (EMC) Directive
- Laser Safety

We confirm that the necessary assessments have been carried out, and the product conforms to the standards set out by the UK government for safety, health, and environmental protection.

## UKCA Marking

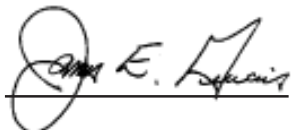
This product is marked with the UKCA mark, indicating compliance with UK legislation and is authorized for sale in Great Britain (England, Wales, and Scotland).

**Affixed Location of UKCA Mark:** On product model number and serial label.

**Manufacturer Name:** LaserStar Technologies Corporation, 2461 Orlando Central Parkway, Orlando, Florida 32809 USA

**Authorized Representative:** GVUK Design, Suite 2C, The Leys, Leyton Road, Harpenden, Hertfordshire ALF 2TL, UK

Signed for and on behalf of LaserStar Technologies Corporation

A handwritten signature in black ink, appearing to read "James E. Gervais".

**James E. Gervais**  
President and Chief Operating Officer

Date: December 3, 2024

# LaserStar Technologies Corporation®

## Library Publication Data

### iWeld® Benchtop 993 Series Welding Workstation

### Setup Guide, Operation & Maintenance Manual

Requests for permission to reproduce or translate whitepapers, technical write-ups, or other publications that are the property of LaserStar Technologies Corporation® (whether for sale or non-commercial distribution) should be addressed to our corporate office (see below for details and methods of contact). No claim to copyright has been made for original bodies of work that have been produced or published by the U.S. Government.

We've distinguished errors and omissions (except for the names of proprietary products that are the property of LaserStar Technologies Corporation®) with capital letters; however, know that this published material is being distributed without warranty of any kind — neither express nor implied. Responsibility for the interpretation and use of this published material lies with the reader; under no circumstance will LaserStar Technologies Corporation® accept liability for damage that arises from its use.

© 2024 LaserStar Technologies Corporation®

<b>LaserStar Technologies: Important Contacts</b>		
<b>Sales &amp; Training</b>	<b>Service &amp; Support</b>	<b>Corporate Office</b>
(407) 248-1142 <a href="mailto:sales@laserstar.net">sales@laserstar.net</a>	1-888-578-7782 <a href="mailto:service@laserstar.net">service@laserstar.net</a>	2461 Orlando Central Pkwy. Orlando, Florida 32809, USA

# Table of Contents

iWeld® Benchtop 993 Series Setup Guide, Operation & Maintenance Manual

Declaration of Conformity . . . . .	4
Declaration of Compliance . . . . .	5
LaserStar Technologies Corporation® . . . . .	7
Library Publication Data . . . . .	7
Background . . . . .	12
<b>I. Introduction</b>	<b>14</b>
Nd:Yag: About, Standards, and Technical Data . . . . .	14
iWeld® Benchtop 993 Series Welding Workstation: . . . . .	16
Equipment Overview . . . . .	16
iWeld® Benchtop 993 Series Welding Workstation: External Components. . . . .	17
and Body Configuration . . . . .	17
Technical Specifications. . . . .	19
Noise Levels. . . . .	20
Embedded Computer . . . . .	21
Controls Circuits . . . . .	21
Optical Viewing System . . . . .	21
Components and Function. . . . .	21
Fundamentals of Laser Light: View Path and Beam Path . . . . .	22
Components, Features & Additional Functionality . . . . .	23
Optical Rail Components . . . . .	24
Computer Controls Unit. . . . .	25
Diagnostics and Self-Checks . . . . .	25
Flashlamp Power Supply, Capacitor Bank, and Simmer Supply . . . . .	25
Heat Exchanger . . . . .	26
Inert Gas and Compressed Air Supply (optional). . . . .	26
Foot Pedal . . . . .	26
Exhaust Unit. . . . .	26
Touchscreen Display and Settings. . . . .	29
Electronic Beam Diameter Adjustment . . . . .	30
Foot Pedal Switch . . . . .	30
Remote Interlock Connector . . . . .	30

# Table of Contents

iWeld® Benchtop 993 Series Setup Guide, Operation & Maintenance Manual

<b>II. Safety</b>	<b>31</b>
Overview and Fundamentals . . . . .	31
General Information . . . . .	31
Fire Hazard. . . . .	33
Essential Safety Information . . . . .	33
Organizational Measures . . . . .	33
Employer Requirements. . . . .	33
Personnel Requirements . . . . .	34
Potential Equipment Dangers . . . . .	34
Protective Devices . . . . .	34
Safety Measures for Normal Use . . . . .	35
Informal Safety Measures . . . . .	35
Personnel Training . . . . .	35
Electric Shock Danger . . . . .	36
Particularly Dangerous Points . . . . .	36
Emission of Noxious Gases and Vapors. . . . .	36
Equipment Modifications: Structural, System, and Software . . . . .	37
Safety Officer. . . . .	37
What To Do If You Receive A Burn . . . . .	38
Scattered Radiation!. . . . .	38
Important Safety & Informational Labels . . . . .	39
<b>III. Installation</b>	<b>42</b>
Overview and Requirements . . . . .	42
Safety Guidelines . . . . .	42
Ambient Conditions . . . . .	42
Environmental Conditions . . . . .	42
Unpacking. . . . .	42
Standard Shipping Container Contents . . . . .	43
Lifting and Carrying the Equipment. . . . .	43
Initial Power Connections . . . . .	44
AC Voltage Input (AC disconnect) . . . . .	44
Securing the Welder with Brackets . . . . .	44
Remote Interlock Connector . . . . .	46
External Exhaust System. . . . .	47
Distilled or Deionized Water . . . . .	47

# Table of Contents

iWeld® Benchtop 993 Series Setup Guide, Operation & Maintenance Manual

Electromagnetic Compatibility . . . . .	47
Disassembly and Transport . . . . .	48
Preparing for Storage . . . . .	48
<b>IV. Operation</b>	<b>49</b>
Overview and Fundamentals . . . . .	49
Initial Operation . . . . .	50
Switching “On” & Switching “Off” the Welder . . . . .	51
Flexible Gas Lines . . . . .	53
Adjusting the Stereo Microscope . . . . .	53
Mounting the Stereo Microscope . . . . .	54
Optical Alignment . . . . .	54
Optical Alignment Diagram . . . . .	55
Setting Operating Parameters . . . . .	56
Touchscreen Display Operation . . . . .	56
Joystick Operation . . . . .	82
Storing Operating Parameters . . . . .	82
Recalling Stored Recipes . . . . .	84
Welding (touchscreen display and joystick) . . . . .	85
Optimizing Welding Results . . . . .	86
Setting Operating Parameters . . . . .	87
Resetting Pulse Count . . . . .	87
Text Input Mode . . . . .	87
Switching “Off” . . . . .	87
Status Monitoring and Indicators . . . . .	88
Floor Stand Operation . . . . .	90
Passwords & Restricted Access . . . . .	91
<b>V. Maintenance</b>	<b>92</b>
Overview and Requirements . . . . .	92
Maintenance Intervals . . . . .	93
Protective Disk Replacement . . . . .	97
Splash-protective Observation Window and Laser Protective Window Replacement . . . . .	98
Filter Replacement and Chamber Exhaust . . . . .	99
Touchscreen Display . . . . .	100

# Table of Contents

iWeld® Benchtop 993 Series Setup Guide, Operation & Maintenance Manual

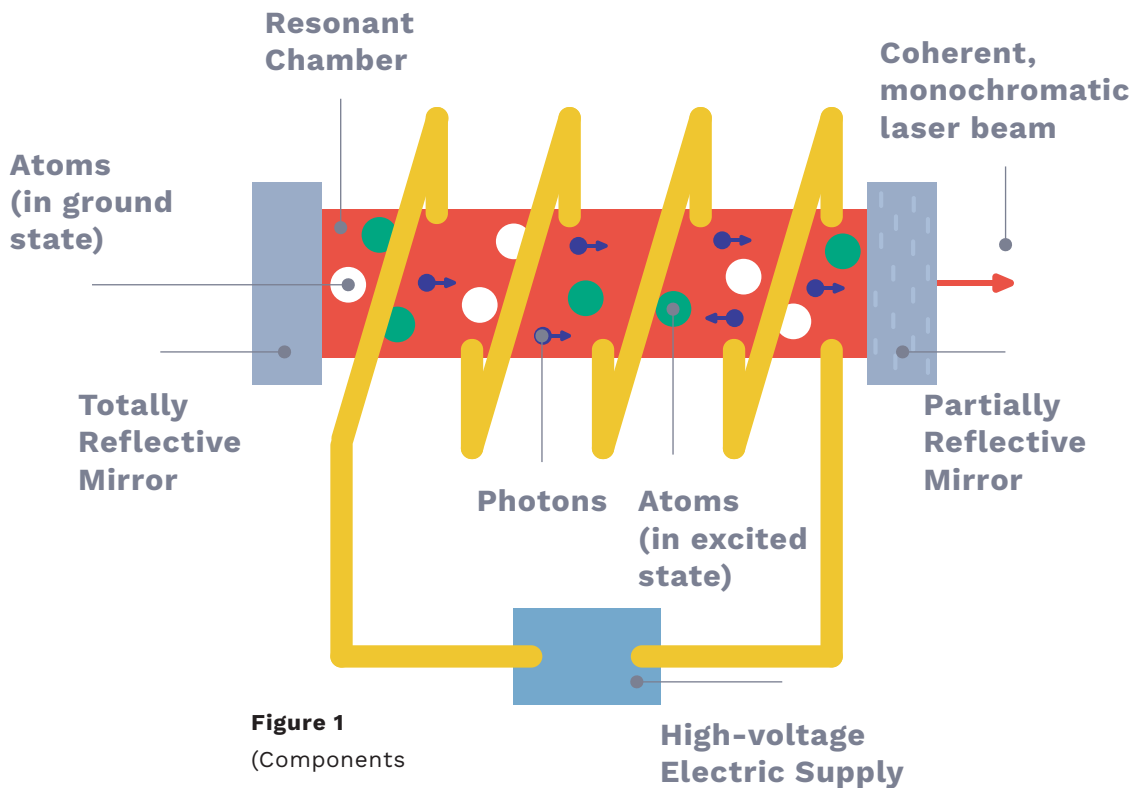
<b>VI. Troubleshooting</b>	<b>101</b>
General Information . . . . .	101
Equipment Malfunction . . . . .	101
Diagnosing & Troubleshooting Basics. . . . .	102
<b>VII. Parts &amp; Accessories</b>	<b>105</b>
<b>VIII. Original Equipment Warranty - Flashlamp Welder Products</b>	<b>108</b>
<b>IX. Service</b>	<b>110</b>
Service A: Distilled or Deionized Water Cooling System. . . . .	111
Service B: Flashlamp Replacement. . . . .	123
Service C: Simmer Supply . . . . .	144
Service D: Cap Charging Supplies . . . . .	145
Service E: Rear System Overview, and External Connections. . . . .	146
Service F: Major Internal System Components . . . . .	147
Service G: Securing the Welder with Brackets . . . . .	150
<b>X. Appendix</b>	<b>151</b>
Appendix A: Single Joystick Configuration, Controls & Operation . . . . .	151
Appendix B: Restricted Access & Password (PIN) Protection . . . . .	154
Appendix C: Cleaning, Service, and Maintenance Intervals Chart (with checklist). . . . .	159
Appendix D: Pulse Performance Profile (P <sup>3</sup> ) Technology . . . . .	161

## Background

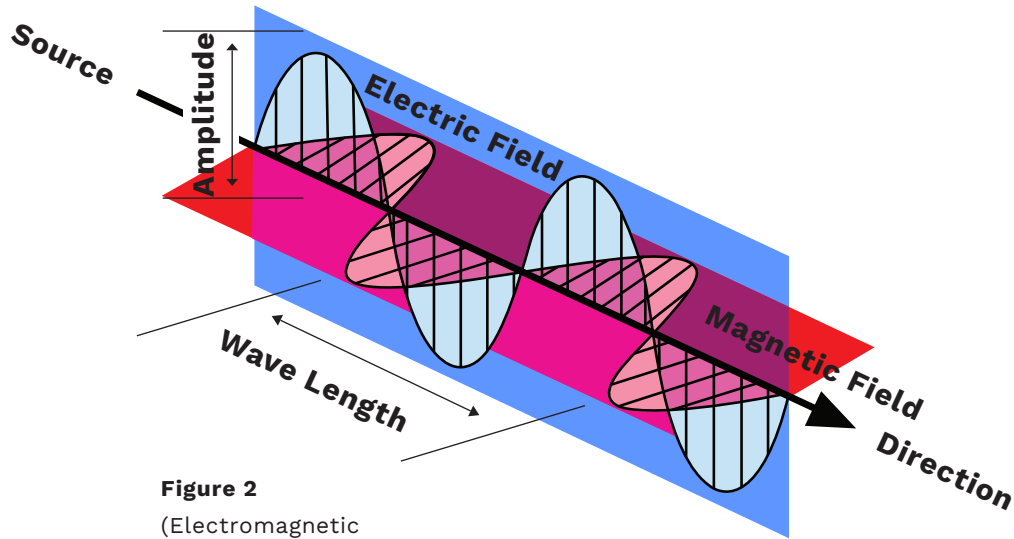
A laser is a device that emits a beam of coherent light through a process of optical amplification (based on the stimulated emission of electromagnetic radiation). The word *laser* is an acronym and stands for **light amplification by stimulated emission of radiation**.

Lasers exist and are made possible because of fundamental interactions between light and matter, or more specifically, electrons — negatively charged subatomic particles that orbit around the nucleus of an atom. These electrons and their associated photon energies exist at specific energy levels (energy levels uniquely dependent on an atom's structure).

Imagine these energy levels as orbits or rings around the sun — electrons within the outer rings produce more energy than those of inner rings. With the introduction of a new energy source (a flash of light), however, electrons can be stimulated or excited to a new energy state, transitioning from a lower-energy orbit to a higher-energy orbit. When they return to their normal or "ground" state, the electrons emit particles of light called photons (**figure 1**).

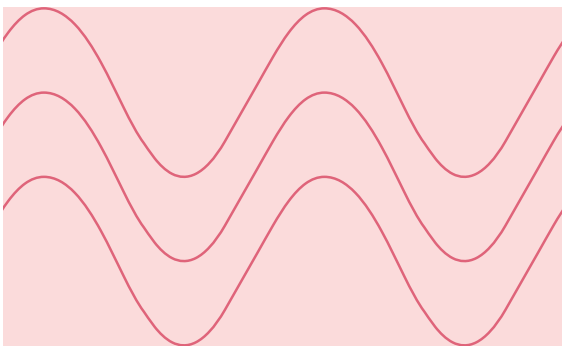


The propagation of light through space can be described as a traveling wave motion — an electromagnetic wave. The wave consists of two fields, each fluctuating — one electric and the other magnetic. The fields remain in-phase and at right angles (orthogonal) to one another — both perpendicular to the direction of travel (**figure 2**).

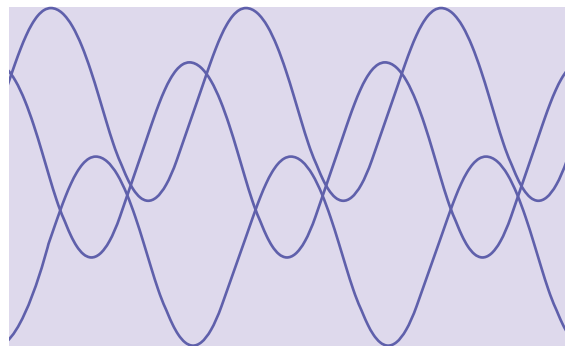


**Figure 2**  
(Electromagnetic wave)

The concept of laser light is better understood by defining and examining its inherent properties. The light outputted from a laser differs from ordinary light and has three (3) defining characteristics that make it unique and help it to stand apart: **coherence**, **monochromaticity**, and **direction**. When all emitted photons bear a constant relationship with one another in both time and phase, the light is said to be coherent. In addition, due to the specificity and purity of the medium, laser light is also monochromatic (one color). Lastly, light emitted from the laser is highly directional, traveling as a relatively narrow beam, in a single direction, and down a specific and pre-determined path (**figures 3 & 4**).



**Figure 3**  
(Coherent,  
monochromatic,  
directional light)

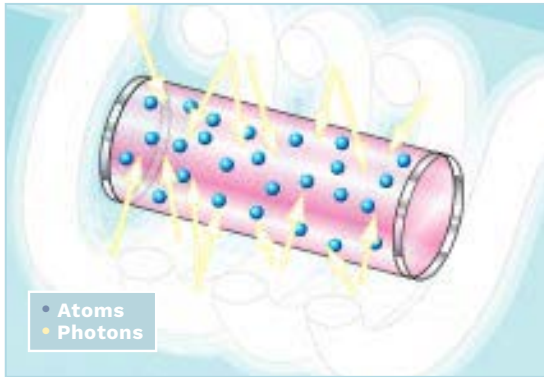


**Figure 4**  
(Incoherent,  
monochromatic  
directional light)

# I. Introduction

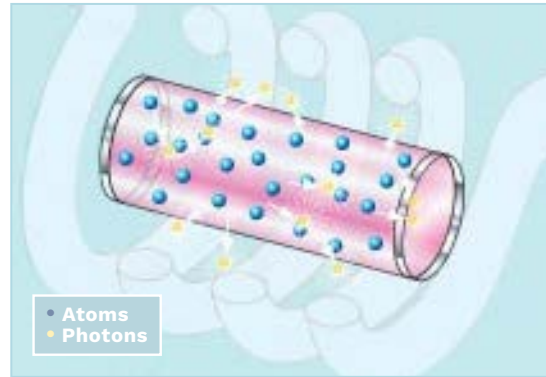
## Nd:Yag: About, Standards, and Technical Data

The iWeld® Benchtop 993 Series Welding Workstation is a solid-state, high-intensity pulsed laser. The device utilizes a crystal compound (neodymium-doped yttrium aluminum garnet; Nd:Y3Al5O12) as the host material and laser medium. Most commonly, infrared light is emitted at 1,064nm.



**Figure 1**

High-voltage electricity causes the flashlamp to emit an intense burst of light, exciting some atoms within the crystal, and causing them to shift to higher energy levels.



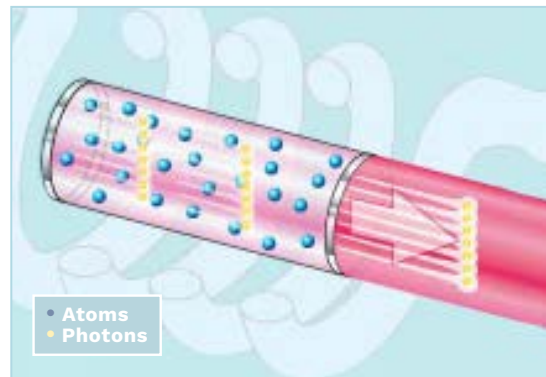
**Figure 2**

After reaching a specific energy level, some atoms emit particles of light called photons; initially the photons are emitted in all directions. As photons from one atom stimulate emissions from other nearby atoms, the light intensity is rapidly amplified.



**Figure 3**

Mirrors resting at the ends of the optical resonant cavity reflect photons back and forth, continuing the process of stimulated emissions and amplification.



**Figure 4**

Photons exit the chamber, through the end of a partially slivered mirror, and thus, we have laser light.

**Nd:Yag: About, Standards, and  
Technical Data Continued on Next Page**

## Nd:Yag: About, Standards, and Technical Data (continued)

**Figures 1–4** (diagrams on the previous page) show a typical resonator or optical resonant cavity. This is where the flashlamp and Nd:YAG crystal compound are located. When intensive light is applied to the crystal via a reflector, it initially produces non-directional light. For optimum utilization of the flashlamp light, both the laser crystal and the flashlamp are arranged just within the “focal point” of an ellipsoidal mirror. A semi-reflecting and a fully reflecting mirror are mounted outside the crystal. Only those parts of the laser light that hit these mirrors are reflected into the laser crystal can be amplified during the pulse of the flashlamp while passing through the crystal. The amplified laser light has the same properties as the original laser light; i.e. it has the same direction, the same wavelength, the same phase and the same polarization. The mirrors determine the highly directional propagation characteristics of the laser light.

Part of the laser light passes through the semi-reflecting mirror and is the laser light that performs the welding function. This process produces a very high energy density light beam, many times higher than is possible with normal light at the focal point of a lens. The energy “hot light” created at the focal point in a relatively short time (0.5 to 20 ms) heats the workpiece beyond its melting point, and thus, enables a weld.

The area affected is in a limited range of only approximately 0.20 to 2mm, depending on the material. the laser light welds two (2) metals together, and thus permits safe, durable, precise and non-warp joining of parts in the form of a spot or seam. Because of the very short time of the laser pulse, the zone of heat influence is limited to the immediate vicinity of the welded spot or seam.

The characteristics of a laser pulse, and thus, the effect on the material, can be influenced by the operating parameters voltage and pulse length (width). The voltage has influence on the amplitude; the pulse length influences the width of the laser pulse.

**In practice, the effect of both parameters while welding metals is as follows:**

- The voltage first influences the welding depth.
- The pulse length predominantly influences the diameter of the welding point.
- The focus influences the welding depth, as well as the diameter of the welding spot. When increasing the diameter, the welding depth is reduced at the same time.

# iWeld® Benchtop 993 Series Welding Workstation:

## Equipment Overview

The iWeld® Benchtop 993 Series Welding Workstation is a highly specialized, portable, stand-alone, single-user operated laser welder designed for metalworking and fabrication. This versatile welding workstation, which is capable of quickly and precisely welding almost any metal or metal alloy, is well-suited for the industrial workspace and a wide variety of complex assembly applications, including spot and seam welding, mold repair, and micro-welding (applicable for industries including, aerospace engineering, computers and information technology, automotive, and medical device technologies).

With welding applications, the workpieces that are to be joined are manually arranged within the illuminated welding work chamber, and are then welded together by means of one or more high-intensity laser pulses.

With welding applications, in order to achieve optimal finalized results, the workpiece must be properly positioned within the focusing area of the laser beam; positioning and workpiece height are determining factors that directly affect the results and outcome. The workpiece height is correct when the surface of the part is in focus while under the microscope.

Laser pulse energy is another factor that can have a direct influence on the quality of the weld; this setting can be adjusted using the software.

The welding workstation is equipped with a stereo microscope with cross-hair, a specialized component within the welding chamber that allows for precise control and positioning of workpieces or parts for achieving consistently reliable welding applications results. The cross-hair marks the exact position of the laser pulse spot on the workpiece.

With any welding application, in order to achieve optimal finalized results, the workpiece must be properly positioned within the focusing area of the laser beam; positioning and workpiece height are determining factors that affect the results and outcome.

The workpiece height is correct when the surface of the part is in focus while under the stereo microscope. Laser pulse energy is another factor that can have a direct influence on the quality of the final weld; pulse energy output can be adjusted with either of the internal welding chamber controls: joystick or keypad. With one control, the intensity of the laser pulse (voltage) is affected and with the other, the pulse length (ms) is altered. Settings for other materials can also be obtained by following the adjustment techniques described.

With certain materials, the quality of the weld can be improved using argon (inert) gas. (Note: This machine is equipped with a separate argon (inert) gas valve.)

The vapor produced during the welding process can be extracted from the lasing chamber and operator's work station using an external exhaust system.

The laser welding workstation is equipped with a foot pedal switch (with two [2] operating positions) that is capable of firing single or multiple laser pulses. The first position (pedal switch slightly depressed) enables the inert gas supply, and the second position (pedal switch fully depressed) releases the laser pulse. **(Note: A multi-functional foot pedal is also available.)**

# iWeld® Benchtop 993 Series Welding Workstation: External Components and Body Configuration



**Figure 5**  
(iWeld® Benchtop  
993 Series Welder)

**External Components and Body Configuration  
Continued on Next Page**

## External Components and Body Configuration (continued)

(The diagram that corresponds with the parts labeling outlined below can be found on the previous page [figure 5].)

1. Stereo Microscope
2. System Key Switch
3. Exhaust Outlet (rear of the machine) and Filter (located inside the welding work chamber)
4. Touchscreen Display
5. Splash-protective Observation Window
6. Hand Opening
7. Welding Chamber Enclosure
8. Illuminated Welding Chamber (internal)
9. Embedded Computer & Controls System (located inside the main body cabinet) and Power Supply Unit (flashlamp power supply, capacitor bank, and heat exchanger; components are located inside the main body cabinet)

- The **welding chamber (8)** is made accessible through the **hand opening (6)**.
- Workpieces or parts within the **illuminated welding chamber (8)** can be observed through the **splash-protective observation window (5)**. The observation window is made from a specialized material and allows for absorption of harmful laser radiation, as well as the ultraviolet (UV) component of plasma light.
- The **stereo microscope (1)**, located at the top of the welding chamber, facilitates effortless positioning and adjustment of parts for welding applications.

## Technical Specifications

The modular construction of the iWeld® Benchtop 993 Series Welding Workstation facilitates efficient, time-saving repairs by allowing for replacement of individual failed modules (non-functional units), as opposed to more intricate repairs that can require extensive downtime and dismantling of the entire machine.

### The welder consists of the following modules, which are configuration dependent:

- Illuminated Welding Chamber (with stereo microscope)
- High-energy Pulse Laser
- Embedded Computer
- Power Supply Unit (flashlamp power supply, capacitor bank, and heat exchanger)
- Inert (argon) Gas Supply and Blast Nozzle (for rapidly cooling workpieces; blast nozzle component is optional)
- Foot Pedal Switch (for triggering laser pulses and inert [argon] gas supply)
- Welding Chamber Exhaust System (with accompanying filter)

<b>iWeld® Benchtop 993 Series Welding Workstation</b>	
<b>A typical system build includes a variety of standard and optional components</b>	
Laser Medium	Nd:YAG Crystal Compound
Laser Wavelength	1.064 μm (infrared)
Beam Divergence (minimum; prior to beam-expanding and focusing optics)	~3 mRad
Pulse Energy (minimum)	180 Joules
Rated power	60 Watts
Pulse Power (maximum)	11 kW (per model)
Single or Multi-Pulse	Selectable Option
Pulse Length	0.5 to 50 ms
Laser Class	Class 4 (operator)
Ambient Conditions: Operating Temperature	5°C to 30°C (41°F to 86°F)
Ambient Conditions: Storage Temperature (water removed)	-10°C to 70°C (14°F to 158°F)
Ambient Conditions: Storage Temperature (with water [not recommended])	3°C (38°F) frost risk
Humidity (operating & storage)	10% to 95% (non-condensing)
Elevation (above sea level)	0 to 6,562 feet (0 to 2,000 meters)
Noise Level (dB)	Varies (model dependent)
Degree of Protection	IPX0
L × W × H	33 × 21 × 43 in (84 × 54 × 110 cm)
Weight	125 lbs (57 kg)
Electrical Requirements: Single-phase (reference machine ID label for specifications [rear of the welder])	15A, 208 – 240VAC, 50 / 60Hz (60W model) 25A, 208 – 240VAC, 50 / 60Hz (80W model)

## Technical Specifications (continued)

### Cooling:

- Internal Water and Air Heat Exchanger
- Distilled or Deionized Water Filter (located inside the internal cooling circuit)
- Cooling Water: 50°C (122°F) or 65°C (149°F; maximum temperature [model dependent])
- Ambient Temperature: 30°C (86°F; maximum)

<b>Inert Gas: Pressure and Flow Regulation</b>		
<b>Operating Pressure (maximum)</b>	<b>Operating Pressure (minimum)</b>	<b>Flow Range (typical)</b>
3.8 bar (59 psi; 0.38 MPa)	0 bar (0 psi; 0 MPa)	10 to 30 CFH

**(Note: To increase cost-savings and offset the expense for inert (argon) gas, the flow rate should be adjusted to the lowest setting possible for achieving the necessary surface finish.)**

### Noise Levels

The audible noise that is continuously produced by the welder can range in decibels (dB) and is model specific.

<b>Power Supplies: Max Output</b>		
<b>Switching Supply</b>	<b>Power Supply</b>	<b>Lamp Simmer Supply</b>
0 – 400VDC	24VDC	1000V / 150V @ 500mA

## Embedded Computer

The embedded computer is connected to the internal controls circuitry and is used for programming and setting welding parameters.

## Controls Circuits

The controls circuits ensure that the welder components are started and stopped in a safe manner (for both the equipment and operator).

### Various controls circuits exist for the following parts:

- Cooling Water (temperature, level, and flow rate)
- External Safety Contacts
- Laser Shutter
- View Shutter (located inside the beam bender under the Stereo Microscope)
- Supply Voltage

## Optical Viewing System

The welder is equipped with an advanced optical viewing system (stereo microscope) with cross-hair functionality. The stereo microscope is a specialized component above the laser welding chamber, and allows for precise positioning of parts for consistently reliable welding applications results. A variety of optical viewing systems and magnification strengths are available.

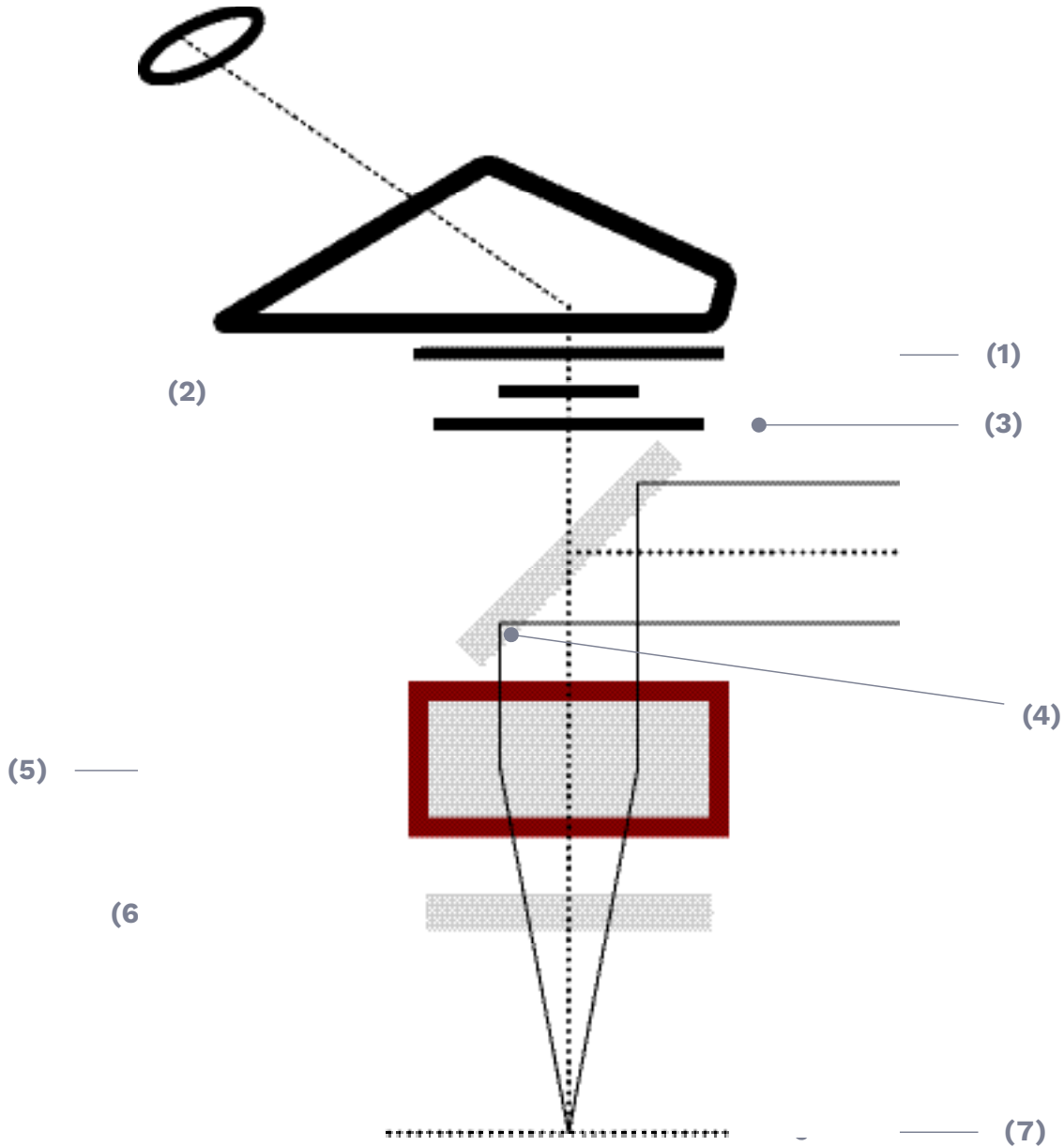
## Components and Function

- Observation Window (used for viewing and observation of application processes within the internal laser welding working chamber)
- Cooling Water (temperature, level, and flow rate)
- Illuminated Welding Chamber with adjustable brightness (by means of the controls within the welding work chamber)
- View Shutter

**(Note: In an effort to protect the operator's eyes, the view shutter will close automatically for a short duration with each laser pulse. The view shutter will close automatically for a short duration with each laser pulse, with an adjustable duty cycle that is set to 25% by default)**

## Fundamentals of Laser Light: View Path and Beam Path

To produce a beam of coherent, monochromatic light, the laser requires an active medium (in this case, optical fibers that have been doped with rare-earth elements), which is positioned between multiple reflectors (mirrors and lenses). These reflectors, which help to perpetuate and distribute the laser's light energy, also ensure the beam continues traveling along its pre-determined path.



**Figure 7**  
(View path and  
beam path)

**Fundamentals of Laser Light:  
View Path and Beam Path Continued on Next Page**

## Fundamentals of Laser Light: View Path and Beam Path (continued)

- The laser beam is channeled through the optical path of the stereo microscope by means of a **highly reflective mirror (4)**.
- A specialized **focusing lens (5)** concentrates the laser beam and directs its focus onto the surface of the **workpiece (7)** that has been positioned within the laser's focusing plane. Additionally, this lens also acts as the focusing lens for the Stereo Microscope.
- The **focusing lens (5)** is safeguarded from dust and metal splashing that is produced during the welding applications process with the aid of a **protective glass lens (6)**.
- The **view shutter (3)** shields and protects the operator's eyes from harmful laser radiation, as well as the ultraviolet (UV) component of plasma light that results from a laser pulse during the welding applications process. With each laser pulse, the **view shutter (3)** will close automatically, obstructing the operator's field of view for a short duration. If there is an interference and the **view shutter (3)** does not properly close, as a precautionary measure, the laser pulse will not be released. **(Note: Workstations with a flat-screen viewing system are not equipped with a view shutter.)**
- Like the **view shutter (3)**, the **laser absorbing filters (1)** protect the operator, blocking out harmful laser radiation and the ultraviolet (UV) component of plasma light to prevent contact with or damage to the eyes.
- The **camera (2)** allows you to project the welding chamber onto a screen.

## Components, Features & Additional Functionality

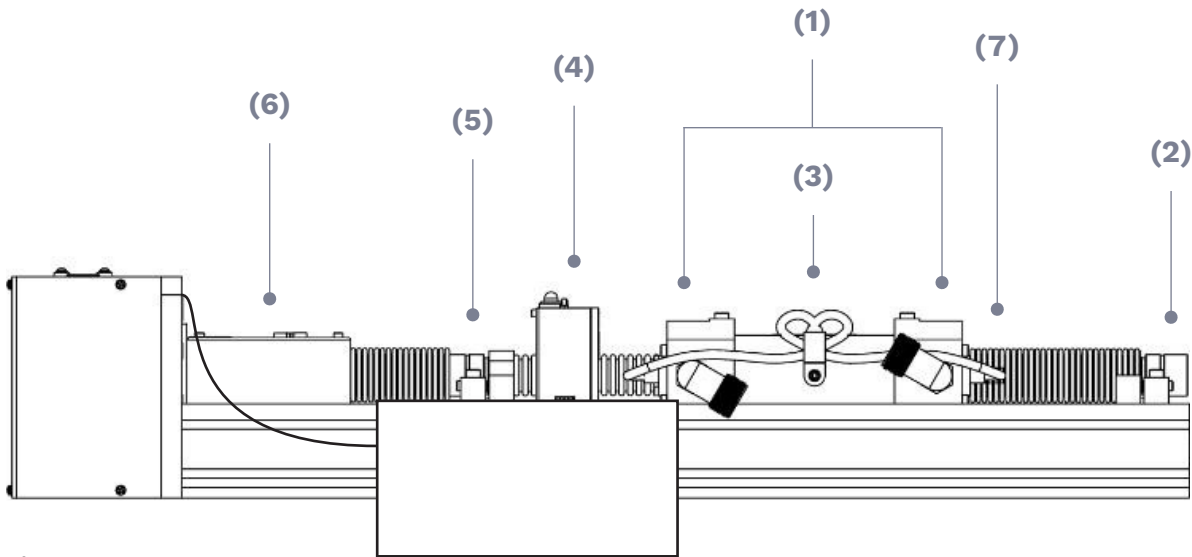
- Storage of Operating Parameters
- Beam Expander (motor-driven [for welding-point diameter])
- Joystick Control (used to set or adjust recipes and welding parameters)
- Inert (argon) Gas Supply (with adjustable nozzle [nozzle is located inside the welding work chamber and positioned in close proximity to the workpiece])

<b>Two-stage Laser Pulse Triggering</b>	
<b>The method below utilizes the foot pedal switch to initiate a laser pulse.</b>	
<b>Stage 1</b>	<b>Stage 2</b>
Inert (argon) Gas Supply	Laser Pulse Triggering

# Laser Delivery System: Standard Optical Rail

## Components & Configuration

The components for this high-intensity pulse laser are mounted on an optical rail. Individual components are explained below with numbers ( ) that correspond to each module's position along the rail system.



**Figure 8**  
(Optical rail configuration)

### Optical Rail Components

- The **pump chamber (1)** contains the flashlamp and crystal compound (neodymium-doped yttrium aluminum garnet). The **ignition unit (3)** is located on the side and bottom of the **pump chamber (1)**.
- The **rear mirror (2)** reflects laser radiation entirely; the **semi-reflecting mirror (5)** transmits a portion of the laser light as useful radiation.
- While in a closed state, the **laser shutter (4)** prevents the formation of harmful radiation. The **laser shutter (4)** remains closed when lowering the voltage or if there is a system fault.
- The diameter of the laser beam can be set by means of a **beam-expander (6)**, which is driven by a stepper motor. When an adjustment is made using the touchscreen or joystick, the diameter of the laser beam in visual focus is adjust accordingly, which spreads the weld energy over a larger spot
- The laser beam and viewing system are coupled by means of a mirror that is highly reflective to the laser. The focusing lens then concentrates the beam onto the surface of the workpiece that has been positioned in clear visual focus.

**Laser Delivery System: Standard Optical Rail**  
**Components & Configuration Continued on Next Page**

## Computer Controls Unit

The computer controls unit is mounted beneath the laser's optical rail. If maintenance or service-related tasks are needed, the controls board is easily accessible from the side of the machine.

### **The computer controls unit is used to control and operate the following components:**

- Flashlamp Power Supply (for laser pulse generation)
- Operating Elements
- Warning Indicators
- Safety Components (view shutter and laser shutter)
- Interlock Circuits Safety Checks

## Diagnostics and Self-Checks

To ensure the welder is functioning correctly, a series of diagnostics or self-tests are executed each time the machine is powered "on."

### **During start-up, this device routinely executes the following self-checks:**

- Cooling Water Flow Rate
- Cooling Water Temperature
- Distilled or Deionized Water Tank Water Level
- Laser Shutter
- Welding Chamber Closed (model dependent)

While the testing sequence is being carried out, the electronic components, power supply, laser shutter, and beam expander are monitored to ensure they are properly functioning. If there is an error or malfunction, the flashlamp power supply will shut down and lasing functions will be deactivated.

When a malfunction occurs, an alert will appear on the controls panel display. When all faults have been eliminated, the flashlamp power supply can be switched "on" again.

## Flashlamp Power Supply, Capacitor Bank, and Simmer Supply

### **The flashlamp power supply is comprised of the following components:**

- Capacitor Bank (forced discharge occurs while the machine is "off")
- Simmer Supply (current power supply with ignition unit)
- Lamp (current control)

After switching on the flashlamp power supply, the flashlamp will be ignited via an ignition coil on top of the excitation unit. After ignition, a small sustaining current flows through the flashlamp (simmer current). The light flash that produces a laser pulse is generated by partially discharging the capacitors of the capacitor bank. For this, a transistor switch connects the charged capacitor bank to the laser flashlamp (triggered by fully pressing the pedal switch).

The "on" time is determined by the set value for the pulse length. During this time, a slight part of the energy stored in the capacitor bank is discharged via the flashlamp and the voltage of the capacitor bank drops. After the end of the lamp pulse, it is automatically recharged to the set reference input value for the voltage (recovery time). This recovery time depends on the set values for pulse length and voltage (pulse height) and needs about 0.1 and 3 seconds. After the power is switched off the resistors will automatically discharge the capacitor bank at a slow rate; allowing the capacitor bank to fully discharge. That should take approximately 30 minutes before handling it.

## **Laser Delivery System: Standard Optical Rail Components & Configuration Continued on Next Page**

## Heat Exchanger

With each flash of light, heat is generated in the flash lamp; the distilled or deionized water is used to effectively cool the flash lamp. A pump draws purified distilled or deionized water from a tank through a combination of a particle filter distilled or deionized filter. The water then circulates past the lamp in the laser pump chamber. This water absorbs the dissipated heat and then expels it into the ambient air through a water/air heat exchanger.

The water is cooled by air circulation. A fan is turned on when the temperature of the cooling water reaches a preset temperature. A flow monitor, a level monitor and an over temperature switch supervise the cooling water circuit and cut off the power supply of the flash lamp in the case of malfunction. **(Note: An alarm message will be displayed on the touchscreen display. Press reset to clear. If the cause of the error has not been corrected, the Alarm message will be displayed.)**

## Inert Gas and Compressed Air Supply (optional)

The device has a connecting socket for inert gas (Argon, nitrogen, etc.) and an optional connecting socket for compressed air (for cooling). The welding chamber / area has a fixed gas nozzle for the inert gas, or an optional factory installed compressed air nozzle.

## Foot Pedal

There is a two-stage foot pedal for activating the inert gas and triggering laser pulses (see the section entitled foot pedal switch; **page 34**).

## Exhaust Unit

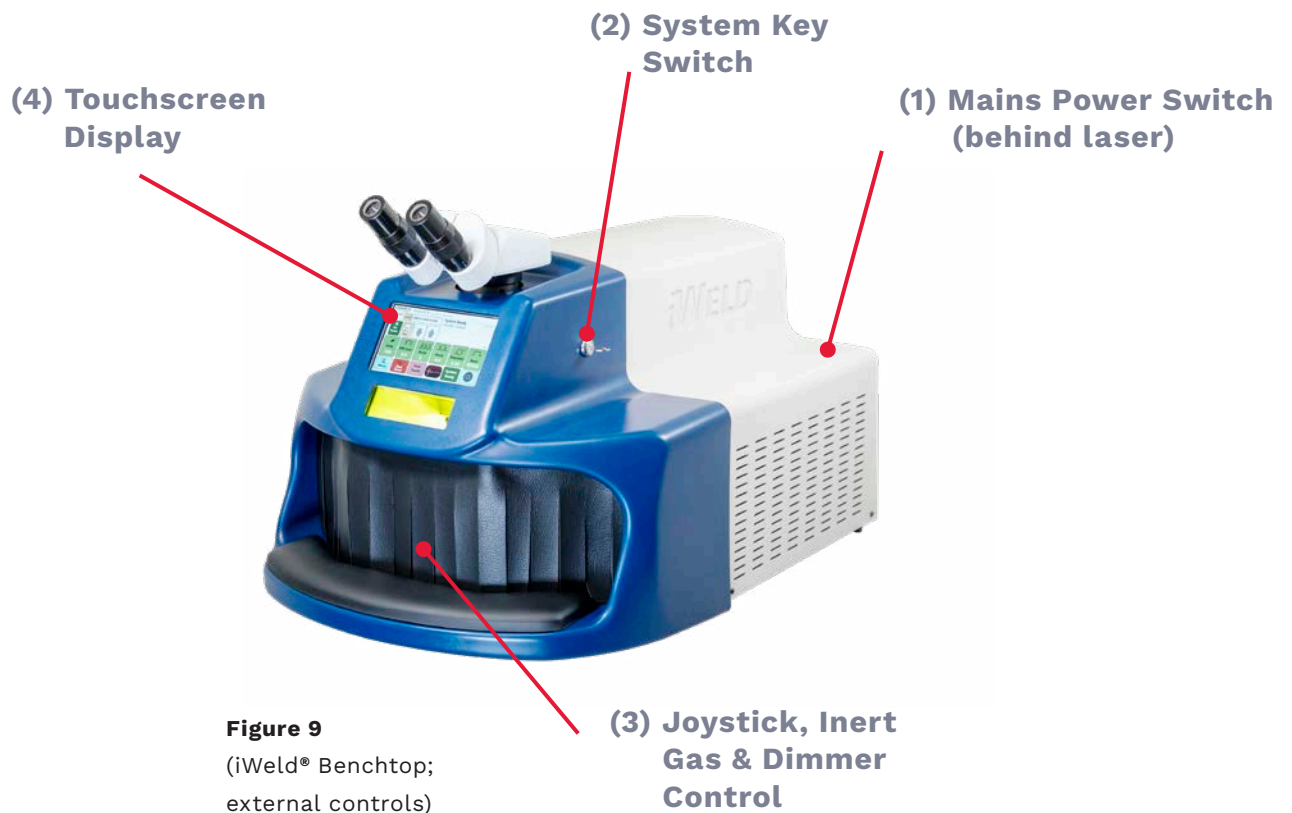
The back of the welding chamber contains an opening through which the vapor produced by welding is exhausted.

If the filtered air is not to be exhausted into the work area, the exhausted air can be directed elsewhere by an adapter with a corresponding hose. The exhaust connector is located in the rear of the laser.



Caution!

**Use of controls or adjustments to performance or procedures other than those specified within this manual can result in hazardous radiation exposure.**



**1. Mains Power Switch:**

The **mains power switch (1)** is used to turn “on” and “off” the machine’s line voltage. In addition, this switch directly powers the Distilled or Deionized water pump. It can be turned “off” (“0” position) in case of an emergency without turning “off” the **system key switch (2)**. **(Note: Complete disconnection from the AC power requires disconnecting the AC plug at the rear of the machine.)**

**2. System Key Switch:**

Using the **system key switch (2)**, the power supply and other system functions can be switched “on.” Without the use of the **system key switch (2)**, these components will not receive power.

**3. Joystick, Inert Gas & Dimmer Control:**

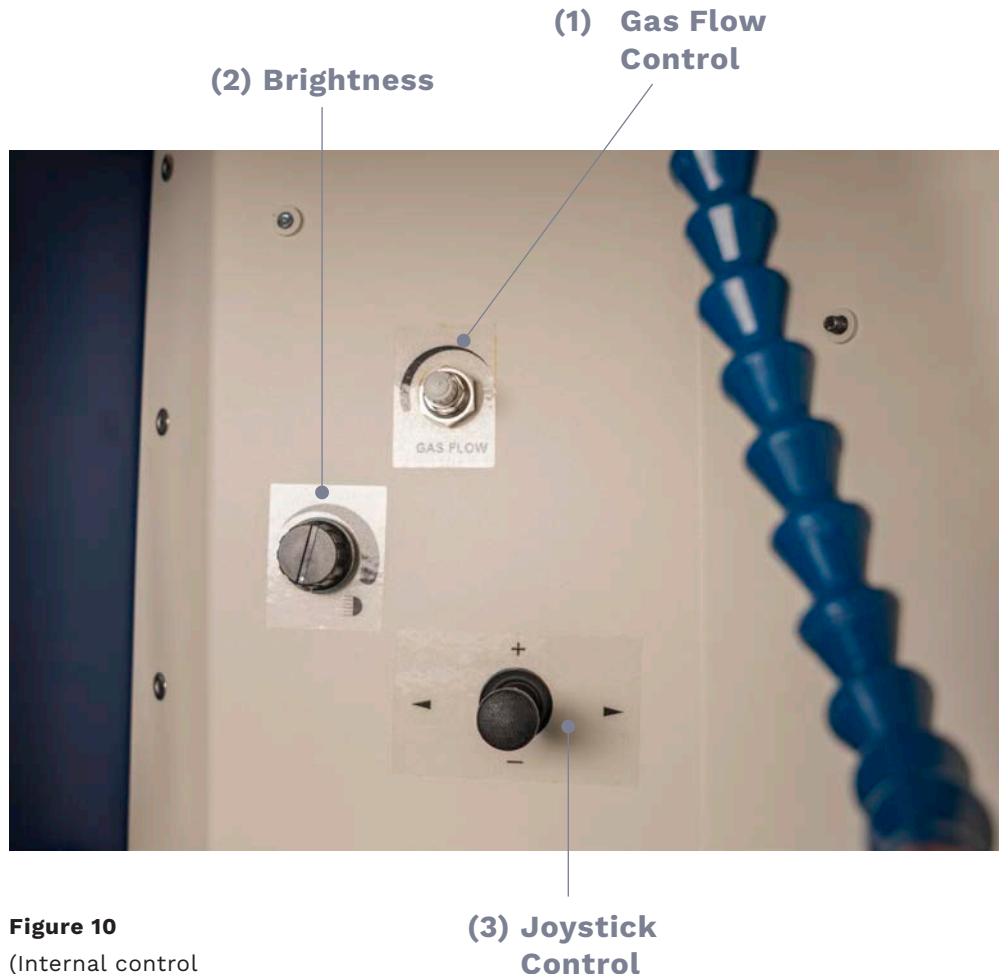
The **joystick, inert gas, and dimmer control (3)** are internal controls, located inside the welding chamber.

**4. Touchscreen Display:**

The touchscreen display relays important details about the machine’s status and displays pertinent data for the device, including voltage, pulse width, Hz, memory mode, integrated preventative maintenance alerts, pre-programmed application parameters; parameter recipes, alarms.

## Internal Control Elements (inside the welding chamber; continued)

On the rear left wall of the welding chamber are the **rotary argon (inert) gas flow control (1)**, **rotary brightness control (2)**, and **joystick (3)**; these control elements are used to adjust the laser pulse intensity, pulse length, and other similar factors.



**Figure 10**  
(Internal control elements; inside the welding chamber)

### 1. **Gas Flow Control:**

The **gas flow control (1a and 1b)** is used to adjust the flow rate of the argon (inert) gas.

### 2. **Brightness:**

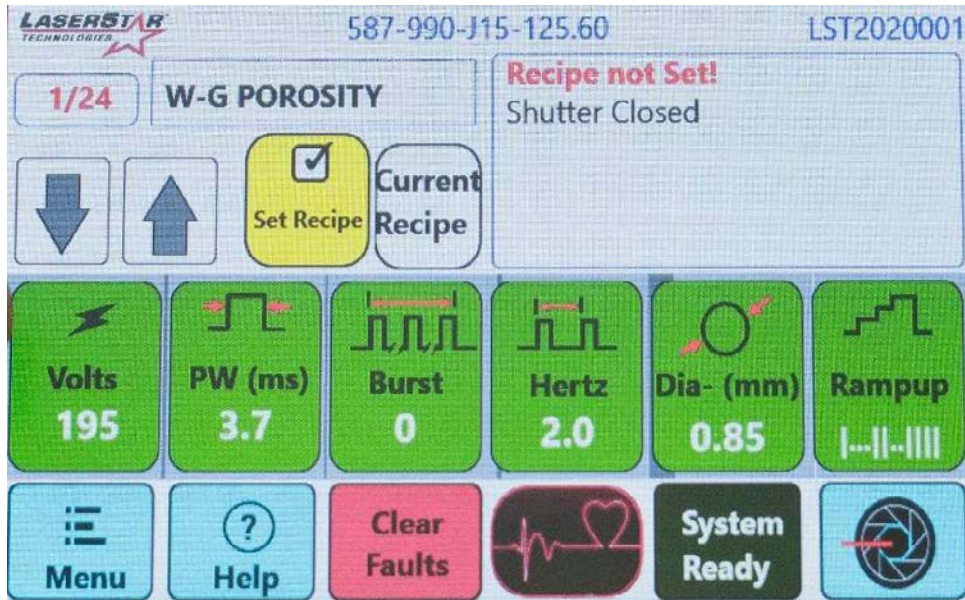
The **brightness (2)** controls the light(s) that illuminate the welding work chamber and allow the operator to view the component that is being welded.

### 3. **Joystick Control:**

The **joystick control (3)** is used for setup and normal operation; it can also be used to adjust parameters and make menu selections.

## Touchscreen Display and Settings

The display layout is shown in **figure 11** below. The first row shows recipe location, description of the recipe and messages; the second row displays operational / mode choices, Arrow Keys, Set Recipe, and current Recipe. The third row Green buttons display weld parameters-Voltage (V), Pulse Length (ms), Pulse Rate (Hz), Burst Mode or Pulse Suppression (optional / model specific), Beam Diameter, and Shape. The fourth row displays Laser Shutter status, System Ready, heartbeat indicator, Clear faults, help and Menu. **(Note: When the heartbeat button indicator is beating, the welder is ready to weld. The Safety Shutter button is used to open and close the safety shutter and displays the status.)**



**Figure 11**  
(Touchscreen  
display)

With exception of the pulse width suppression, all parameters can be set using the touchscreen display, or alternatively, the joystick or keypad controls (located inside the welding chamber). For additional details on the internal controls, be sure to reference the **internal control elements** and corresponding diagram on the previous page; **page 32**.



**Attention: To preserve the touchscreen display and extend the life of this digital device, you should refrain from using inappropriate items (i.e. pencils, pointers, pens, etc.) to press buttons or interact with the digital display. Using these and other unsuitable items can cause the touchscreen display to malfunction, resulting in erratic or faulty operation. This will reduce the lifetime of the touchscreen device and also void the machine's warranty.**

**Fingers (not finger nails) or a soft stylus pen are the only acceptable instruments that should be used when interacting with the touchscreen display.**

## Electronic Beam Diameter Adjustment

The electronic beam diameter is controlled by the touchscreen display or joystick. Using the joystick, the beam diameter is selected the same way as voltage or other parameters on the touchscreen display. The beam diameter range is 0.1-2.00mm.

## Foot Pedal Switch

The welder workstation is equipped with a foot pedal switch for triggering laser pulses and the inert gas. The foot pedal is connected to the machine via a single flexible cable and can be moved or repositioned by the operator, as needed.

### **The foot pedal switch has two (2) operating positions with the following functions:**

#### Stage 1:

Depress the foot pedal, partially, until you notice initial resistance; this will trigger the inert (argon) gas supply to switch “on.”

#### Stage 2:

Depress the foot pedal, fully, until it reaches the floor; this will trigger a laser pulse. If the inert gas supply is connected to the welder, it will remain “on” until the foot pedal has been fully released.

### **When releasing pulses consecutively, the following options are available:**

- You can release the foot pedal slightly after each pulse and then push it right down again.
- If the pulse frequency is set for multi-pulse mode (Hz), the laser can release a continuous series of pulses by depressing and holding down the foot pedal.
- If the Burst Mode (B) is set, the laser will release up to the number of pulses that the operator chooses by depressing and holding the foot pedal.

## Remote Interlock Connector

There is a remote interlock connector available to readily connect the device to a secondary interlock circuit (such as an entry door) into a specific laser room. The remote interlock can be bypassed by using the remote interlock shorting cap, p/n 101-36-0036. Refer to **Installation, section III** for instructions on connecting or bypassing this feature. For the location of the remote interlock connector, refer to Service, External Fuses & Rear Connections.

## II. Safety

### Overview and Fundamentals

Radiation produced by laser light is capable of melting, burning or vaporizing almost any material. The composition of the workpiece also dictates the vapor or gases that are generated; therefore, appropriate safety precautions are essential and critically important.

The iWeld® Benchtop 993 Series Welding Workstation is designed exclusively for welding applications, including both metals and metal alloys. To use the welder for any other purpose (or for anything beyond what has been outlined in this operation manual) is to use it improperly. LaserStar Technologies Corporation® will not accept liability for damages resulting from improper use or negligence.

### Proper use of the welder includes:

- Following all instructions and procedures and heeding all precautions, warnings, and important safety guidelines provided throughout this manual.
- Ensuring inspections and routine maintenance intervals are scheduled and completed on time to maintain the welding workstation and preserve the equipment in its optimal condition.

In addition to general information and noted mandatory regulations that help to ensure safe operation of this equipment, this section also contains information on dangers that cannot be eliminated (either by design or structural means). These advisories are marked with varying safety symbols (examples follow) and are a mandatory requirement set forth by OSHA and CDRH.



**Indicates a potential threat or danger to health or life. Failure to heed this advisory can result in serious damage, critical injury, and death.**



**Indicates a potentially dangerous situation. Failure to heed this advisory can result in minor injury or property damage.**



**Indicates important guidelines for correct use of the welding workstation. Failure to heed this advisory can result in malfunctions or problems with the equipment and additionally, may cause damage to areas and property that is in close proximity to the machine.**



**Indicates safe operating guidelines, tips and recommendations, and particularly useful details that will help you to better utilize all of the functions of your laser welder.**

### General Information

The iWeld® Benchtop 993 Series Welding Workstation is a **Class 4** laser (solid-state; Nd:YAG) with a high-powered optical output. The invisible laser radiation that is generated during the welding applications process produces a wavelength of 1064nm (near infrared range) and is **not detectable by the human eye**. In addition, the visible secondary radiation that is emitted from this device can cause dazzle effects when viewed for any length of time.



The unprotected eye is particularly endangered by the effects of laser radiation. Irrecoverable damaged can occur following contact with direct or reflected beams; the effects are delayed and may not become apparent for many years. Infrared light is transmitted from the cornea to the lens of the eye, which narrowly focuses it on the retina, concentrating the radiant exposure from the laser by up to 100,000 times. Since the tissue structures of the retina cannot be repaired, lesions caused by the focusing of visible or near-infrared light on the retina can be permanent, resulting in a reduction or loss of eyesight. Therefore, when working with direct access to the laser beam (during general use, maintenance or repair) appropriate laser protective eyewear must always be worn.

Always follow OSHA regulations, ANSI Z136.1-2014, Safe Use of Lasers or the equivalent national or international regulations (e.g. IEC / EN Standard 60825-1:2014) to ensure accident prevention and reduce risk of exposure to radiation when working with laser equipment.



If a modification by the user affects any aspect of the performance, data or intended function of the machine (as described in the relevant standards of a previously classified laser device), the person or organization that carried out the modification is responsible for obtaining a newly revised classification and labeling for the device. This person or organization also then assumes the status of “manufacturer.”

**Laser eyewear with an OD >6.5** at the laser wavelength (**Order No. 444-IR-101-7-60**) is **mandatory** to provide protection against direct, reflected, and scattered radiation, however, even if protective laser eyewear is worn, never look directly at the laser beam. Intense laser radiation is capable of destroying the delicate tissues of the eye. Serious dangers exists from exposure to direct, reflected, and diffused or scattered radiation. **(Note: In Class 4 operation of the machine, the protective laser eyewear will normally protect against the hazards of collateral radiation [e.g. ultraviolet, visible, and infrared], however, if a concern exists that the accessible collateral radiation might be hazardous, the end-user is responsible for review and consideration of the MPE values required for the various materials being processed.)**



When operated without the workspace protective housing or Front Door (model dependent), all persons in the NOHA (Nominal Ocular Hazard Area) must wear appropriate laser protective eyewear (OD >6.5). The laser protective eyewear must meet the safety requirements for the relevant laser output power. The maximum radiant exposure (10cm from laser focus) is 32J/cm<sup>2</sup>. The MPE (Maximum Permissible Exposure [@1s]) is 30uJ/cm<sup>2</sup>. The NOHD (Nominal Ocular Hazard Distance) is 150m from the laser focus (120mm focus lens @1s exposure).



Although the skin can withstand considerably higher radiation intensity than the eye tissue, burning destroys the tissue. The severity and extent of damage depends on the period of exposure and the intensity of the irradiation. Appropriate protective clothing should be worn to protect the skin whenever necessary.

**If a laser injury (or a suspected laser injury) occurs while using the laser welder, be sure to complete the following steps right away:**

- Turn “OFF” the machine’s **Main Power Switch**
- Notify the Safety Officer or Safety Specialist
- Consult a doctor or go to the hospital

## **Fire Hazard**

The intense power output from this **Class 4** laser can pose a fire hazard; a wide range of materials are susceptible and measures must be taken to prevent fires while the laser beam is active. Paper items (including diagrams, leaflets or even posters on the wall), curtains lacking fire retardant, wooden panels or other similar materials can be easily set on fire by direct or reflected laser radiation.

Containers holding flammable or explosive chemical agents (e.g. used for cleaning and maintenance tasks) should be kept away from the areas that are exposed to the laser beam. When using solvents or cleaning agents, be sure to heed relevant warnings. Significant explosions, fires, and other dangers can result if such containers are inadvertently exposed to or destroyed by the intense invisible laser beam.

## **Essential Safety Information**

**The guidelines below ensure the safe operation of the welder workstation:**

- This operation manual contains guidelines and important information for ensuring the safety of the operator and outlines procedures for proper use of the welding workstation.
- Anyone who works with or operates the laser welder must be informed on pertinent safety information and applicable safety regulations; this is a prerequisite for safe, trouble-free operation of this machine.
- Anyone who works with or operates the laser welder is expected to follow (and be knowledgeable of) the outlined operational procedures; especially the guidelines for safety.
- Mandatory regulations and requirements for ensuring safety and accident prevention (that are relevant for the current place of installation) must be complied with. Additionally, regulations set forth by OSHA, ANSI Z136.1-2014, Safe Use of Lasers or equivalent national or international regulations (e.g. IEC / EN Standard 60825-1:2014 are especially critical. Lastly, be sure to stay informed and adhere to all required state, municipalities or local regulations and requirements.

## **Organizational Measures**

The employer must provide the necessary personal safety equipment (in this case, laser protective eye-wear is required only for maintenance purposes) whenever there is direct access to the laser beam.

Regulations and requirements outlined in accordance with OSHA regulations, ANSI Z136.1-2014, Safe Use of Lasers or equivalent national or international regulations (e.g. IEC / EN Standard 60825-1:2014) must also be fulfilled.

The laser welder must always be maintained as instructed within this operation manual.

## **Employer Requirements**

**Only authorized personnel with adequate training are permitted to use and operate the laser welder. Employers are responsible for ensuring that authorized personnel:**

- Are familiar with important regulations concerning safety at work and accident prevention; employees must also have received instruction on the use of the laser system;
- Have read and understood the chapter in this manual concerning safety and be familiar with relevant warnings; employees should sign and acknowledge that these requirements have been met;
- Receive training and instruction on the dangerous effects of laser radiation in accordance with OSHA regulations, ANSI Z136.1-2014, Safe Use of Lasers or equivalent national or international regulations (e.g. IEC / EN Standard 60825-1:2014) to ensure accident prevention when working with laser equipment;
- Receive ongoing training at regular intervals on operation, safety measures, and best practices when using the laser welder.

# Personnel Requirements

## Personnel who are trained and authorized to work with the laser welder are expected to:

- Comply with important regulations concerning safety at work and accident prevention for laser radiation, OSHA regulations, ANSI Z136.1-2014, Safe Use of Lasers or the equivalent national or international regulations (e.g. IEC/EN Standard 60825-1:2014).
- Have read and understood the chapter within this manual regarding safety and be familiar with the warnings noted throughout this manual; employees should sign and acknowledge that these requirements have been met.

## Potential Equipment Dangers

The iWeld Benchtop 993 Series Welding Workstation is a state-of-the-art device, **meticulously designed and engineered to meet and exceed standards for safety and approved operation and safety regulations.** Nevertheless, use of this equipment can still endanger life and limb (both the operator and third parties) or damage products and other material assets.

**Keeping in mind these and other practical safety measures, it is vital that the welder be used only in the following ways and with these expectations:**



Warning!

**The welding workstation must only be used for its intended purpose as outlined in this manual (see details on proper use). In addition, the machine must also remain functionally sound (and in optimal condition) from the standpoint of safety.**

**If a malfunction occurs that creates an unsafe condition or negative consequence, it must be corrected right away.**

## Protective Devices

- Before each use, the safety mechanisms for the laser welder must all be checked to ensure they are correctly mounted and properly functioning.
- Safety mechanisms may only be removed when the laser welder has been switched “OFF” and appropriate measures have been taken to prevent the machine from being restarted. **(Note: The interlock switches can be bypassed by our service technicians and authorized specialists, if needed, but only when making adjustments or carrying out maintenance.)**

## Informal Safety Measures



Warning!

- **The operating instructions for the welding workstation must remain at the installation site. In addition to the instructions, applicable regulations for ensuring safety when working with or operating laser equipment (including applicable local regulations for accident prevention and environmental protection) must be complied with. Regulations set forth by OSHA, ANSI Z136.1–2014, Safe Use of Lasers or the equivalent national or international regulations (e.g. IEC/EN Standard 60825–1:2014) are also critically important.**
- **All safety information and warning labels that are attached to the machine must remain intact, legible, and accessible (see the section entitled “Labeling”).**

## Personnel Training



Warning!

- **Only qualified personnel who receive adequate training and instruction on accident prevention and associated dangers when working with laser radiation (as required by OSHA, ANSI Z136.1–2014, Safe Use of Lasers or the equivalent national or international regulations [e.g. IEC/EN Standard 60825–1:2014]) are permitted to operate the laser welder.**
- **Trainees are only permitted to use the machine while under the supervision of an experienced user.**

## Safety Measures for Normal Use

- Before using the machine, you must verify that all of the safety mechanisms (remote interlock, enclosure, front door safety interlock, laser protective eyewear, etc.) are properly functioning.
- Check the machine at least once a week for external damage and to ensure soundness of all safety mechanisms and other components are properly functioning (e.g. protective viewing windows, interlock circuits, welding chamber enclosure, chamber controls, protective flaps, and guards). The welder can only be used after routine safety checks are performed and the machine is deemed to be in safe and operable condition.

## Electric Shock Danger



- Only authorized personnel are permitted to carry out maintenance work on the power supply.
- The housing for the internal components must remain closed at all times. Only authorized personnel who are specially trained (and possess the appropriate tools) are permitted to open the housing and perform maintenance on the internal components.
- If work is to be carried out on voltage-carrying parts, a second person must be present who can switch the device “off” using the power switch, if necessary (see section entitled “Notes on Maintenance”).

## Particularly Dangerous Points



- Particularly dangerous points must be labeled as such. The various warning labels and their location on the machine are described in the section entitled “Labeling.”
- There is increased danger when the welding chamber is open and the interlock switches are simultaneously bridged (model dependent).
- Above all, never operate the laser while your hands, fingers or other body parts are positioned directly inside or beneath the cross-hair or path of the laser beam.

## Emission of Noxious Gases and Vapors



- Avoid inhalation of vapors produced during the welding applications process with correct use of the argon (inert) gas.
- Radiation produced by laser light is capable of melting, burning or vaporizing almost any material. The composition of the work piece also dictates the vapor or gases that are generated; therefore, appropriate safety precautions are essential and critically important. The operator should filter the air exhausted as required by OSHA regulations (for further details, reference the section on installation).
- Never use this machine on non-metallic materials, especially plastics.

## Equipment Modifications: Structural, System, and Software

- + **Never attempt to make additions or modifications to this equipment (structural or otherwise); any alteration requires mandatory written approval from LaserStar Technologies Corporation®.**
- + **It's important that this device be maintained as intended and kept in safe and operable condition. Be sure to immediately replace all parts that are not in optimal working condition. Never purchase or install components from other manufacturers; use only LaserStar Technologies Corporation® replacement and consumable parts.**

### **Important Advisory:**

Parts ordered from LaserStar Technologies Corporation® meet stipulated requirements for safety and performance; **there is no guarantee for parts purchased from companies other than LaserStar Technologies Corporation®.**

## Safety Officer

**When class 4 laser equipment is installed, the employer must appoint a competent Laser Safety Officer;** this action must be recorded in writing. In the case of **class 1** laser devices, the Laser Safety Officer need only be present while the service technician is carrying out service or maintenance on the equipment (and only when there's direct access to the laser beam). This assumes that the service technician bypasses the interlock switches or removes the protective covers from the machine.

With ongoing training and experience in the field of laser radiation, the Laser Safety Officer should be fully competent in operating the welding workstation. In addition, this person should **be knowledgeable and informed on all important safety protocols for the machine, as the Laser Safety Officer bears full responsibility for the safe operation of the laser equipment and correct implementation of mandatory safety measures.**

When completing training for proper use of the welding workstation, the Laser Safety Officer may elect to receive instruction from an approved body (e.g. an institution providing insurance against occupational accidents) or alternatively, can purchase and enroll in training provided by LaserStar Technologies Corporation®.



Caution!

**Authorized personnel with responsibilities for the operation, maintenance, or repair of this device must read and understand both the safety protocols and operating instructions for the equipment. Be sure to use this device only for its intended purpose; never aim the laser's beam in the direction of or directly at humans or animals.**

## **What To Do If You Receive A Burn**

In the event of a burn due to a laser pulse seek immediate treatment. Depending on the severity of the burn, medical treatment may be necessary. Although a small burn is not particularly critical, it must still be monitored to be sure there is no resulting infection.

### **Scattered Radiation!**



**Scattered radiation can also cause minor burns on the skin of your hand. Depending on the material, its reflective properties, and the selected pulse energy, scattered radiation can also be dangerous. Only under very unfavorable circumstances will the scattered radiation reach intensities that can cause slight burns; this is because individual laser pulses are very short.**

Normal exposure of the skin to low levels of scattered radiation (at a wavelength of 1064nm) is regarded as physiologically safe; in this instance, infrared light is comparable with radiation from the sun.

### **Notes**

---

---

---

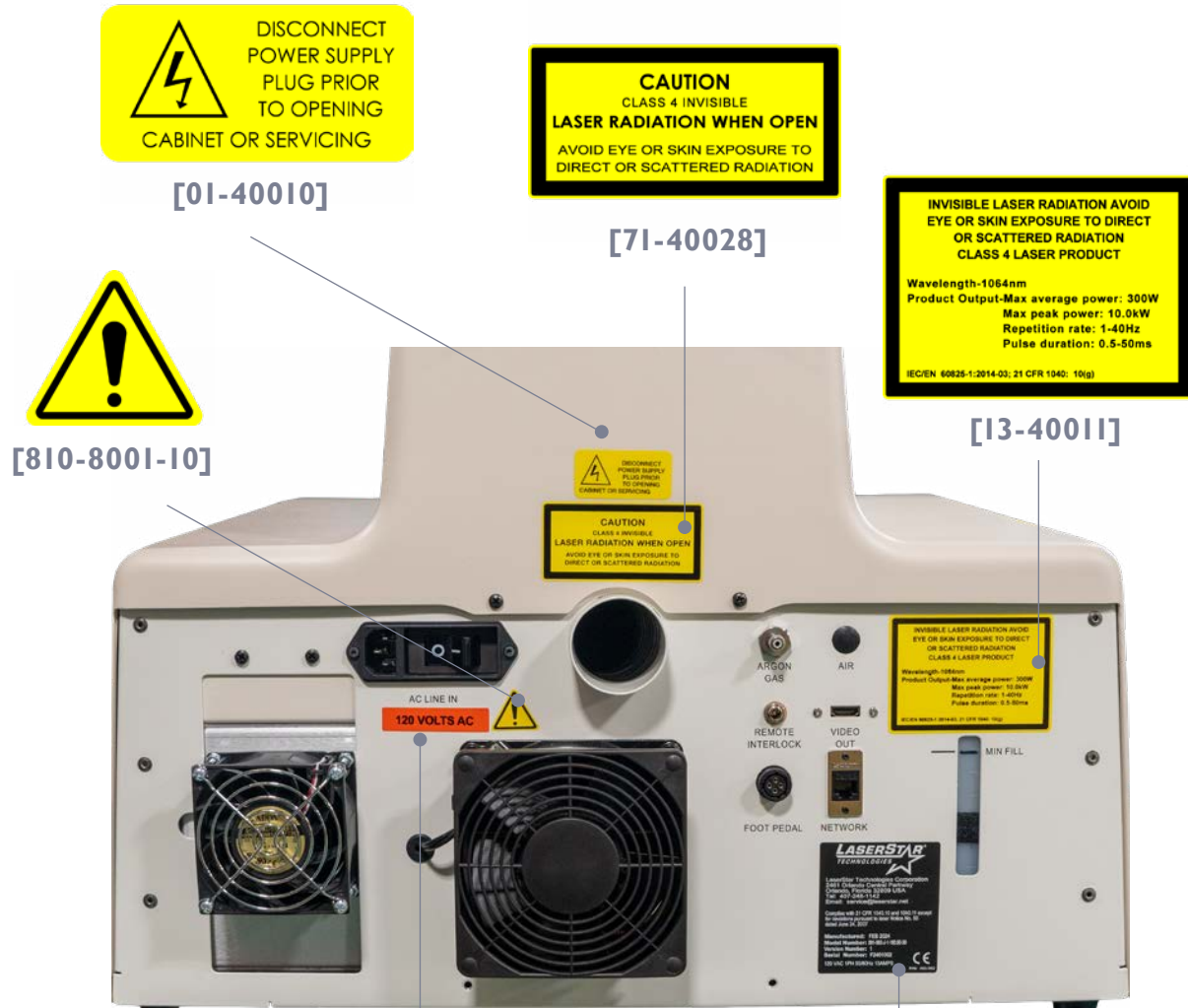
---

---

---

---

# Important Safety & Informational Labels



**Figure 1**  
(iWeld® Benchtop  
993 Series Welder)

**[479-3404]**  
AC Voltage Label (Note:  
Same VAC rating  
as Certificate or Machine  
ID Label)

**120VOLTS AC**

**[403-xxx]**  
Model  
Dependent



## Important Safety & Informational Labels [continued]



**Figure 2**  
(View Window)

[71-40026]

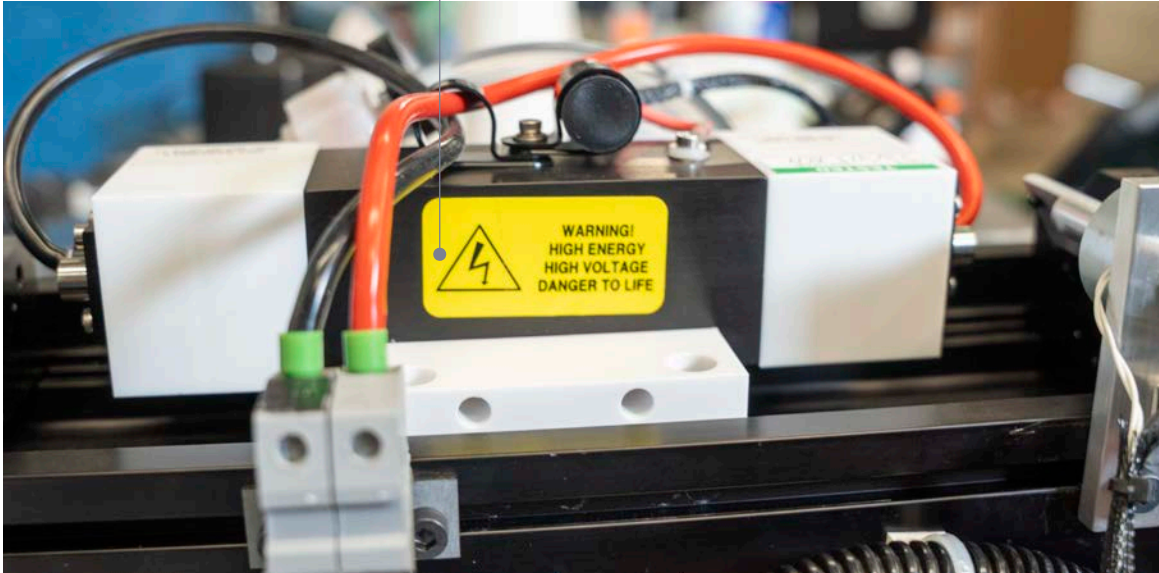


**Important Safety & Informational Labels  
Continued on Next Page**

# Important Safety & Informational Labels [continued]



[01-40009]



**Figure 3**  
(Pump Chamber)

**120 VOLTS**  
[479-3404]



[81-8002-27]



**Figure 4**  
(Cap Charger)

# III. Installation

## Overview and Requirements

This section describes the requirements that must be fulfilled to ensure faultless operation of the welding workstation. Details for installation, setup, and transport are also provided in this chapter.

## Safety Guidelines

**In an effort to safeguard against accidents, an installation site must meet and abide by the following rules and requirements:**

- The welder should be installed in and remain in a location that is as dust-free as possible.
- Never expose the machine to direct sunlight.
- To ensure proper ventilation, the minimum clearance between the welder and any wall surface must be a minimum of at least 12” (300mm) from the back and sides.
- Never position the equipment in a way that makes it difficult to access or operate the machine's disconnecting device.
- The welder must be connected to an approved external filtration and fume exhaust system (either purchased separately or through Laser-Star Technologies®). For details on setup and assembly, be sure to reference the included quick setup guide: External Fume and Heavy Particle Exhaust and Optional Cyclone – Quick Setup Guide.



Caution!

**When choosing an installation site, you must take into account for maintenance, the ability to limit laser area is recommended (see regulations set forth by OSHA regarding accident prevention for laser radiation, ANSI Z136. 1–2014, Safe Use of Lasers, or equivalent national or international regulations (e.g. IEC/EN Standard 60825–1:2014))**

## Ambient Conditions

Operating Temperature: (reference **Introduction > Technical Specifications; section I**)

Storage Temperature: (reference **Introduction > Technical Specifications; section I**)

**(Note: If the laser welder contains cooling water, do not store or transport when temperatures are below 3°C [frost risk]).**



Warning!

**Never add antifreeze solution to de-ionized cooling water.**

## Environmental Conditions

Elevation: (reference **Introduction > Technical Specifications; section I**)

Relative Humidity: (reference **Introduction > Technical Specifications; section I**)

## Unpacking



Warning!

**This equipment has been thoroughly inspected and tested prior to shipping; the welder has been delivered in faultless condition. Before opening the shipping container, be sure to thoroughly inspect the outside of the crate for indications of damage that may have occurred in transit.**

- If possible, transport the equipment to its final destination using the supplied skid.
- When unpacking the equipment, be sure to carefully remove the machine from the shipping container, packaging, and skid base.
- For helpful tips and step-by-step instructions on setup, be sure to reference the included quick setup guide: iWeld Industrial 1901 Series Laser Welding System – Quick Setup Guide in the back of this manual.

## Standard Shipping Container Contents

- iWeld® Benchtop 993 Series Welding Workstation (stand-alone; without accessories)
- Viewing System
- Distilled or Deionized Water
- Operation Manual (digitized version; included on flash drive)

**(Note: Deliveries can include additional optional accessories. Following drop-off, be sure to reference the packing slip and compare with parts received.)**

## Lifting and Carrying the Equipment

- The welder should be lifted and carried from the base of the unit; never support or carry the machine from the door handle or other interior or exterior components.
- A minimum of two (2) people who are capable of lifting and carrying the equipment is required.
- Lifting methods are determined based on the weight and size of the unit, as well as the user's facility requirements. Be sure also to check OSHA guidelines for information on appropriate lifting techniques.

### Notes

---

---

---

---

---

---

---

---

---

---

## Initial Power Connections

The activities described in this section should only be performed by trained service technicians who are affiliated with LaserStar Technologies Corporation® or other authorized personnel who are trained and qualified. Warranty claims for damage to persons or property that are the result of an improperly connected device will not be honored.



**Check the VAC label and device's certificate or ID label (located on the rear of the machine) and compare with the power requirements at the installation site.**

## AC Voltage Input (AC disconnect)

The AC voltage input is used to supply AC power to the workstation; removing this plug will disconnect the AC power from the device. Before applying AC voltage, each of the device's switches (**mains power switch, system key switch, and setup key switch**) should be "off."

The machine's model is the determining factor for establishing AC requirements; check that the AC supply agrees with the specifications on the device's certificate or ID label (located on the rear of the welder). This label includes important information for your laser workstation, including the device's model number, serial number, and AC requirements. **Attention: Make sure the workstation is grounded; the ground wire must be connected for safe and reliable operation.**

When replacing the detachable mains supply cord, it's important that the new cord be appropriately rated and suitable for the required or anticipated electrical load. Be sure to check the rating for the replacement cord before purchase; **never use or purchase cords that lack an appropriate rating.**

## Securing the Welder with Brackets

There are four (x4) brackets located on the welder for those applications that require the workstation be secured to a tabletop for increased stability (for locations, see **figure 4** on the next page). In addition to improving stability, brackets also prevent accidental tipping of this device and should always be used. To install brackets on your machine, simply unscrew the fasteners securing each of the feet (or bumpers) and install the supplied brackets.



Caution!

**Attention: Brackets and screws for securing the welder are fastened to the machine before transport; be sure not to mistakenly discard these.**

**Securing the Welder with Brackets Continued on Next Page**

## Securing the Welder with Brackets (continued)



**Figure 4**  
(Brackets installation)

If you purchased the standalone laser, brackets are supplied for applications that require the welder to be secured to a tabletop for increased stability. The instructions that follow show the method for securely mounting the iWeld to a table surface.

Locate the two (2) anchor brackets within the accessory kit (provided). Using a socket wrench with an 8mm socket, remove the two (2) bolts from the bottom rear of the laser. (Note: A 5/16" socket will work, as well.)

With the slotted side of the bracket facing toward the laser welder, thread the bolt into the hole, and use the socket wrench to secure the brackets to the rear of the laser.

Securely fasten the brackets to the tabletop using the appropriate anchor bolts or screws.

## Remote Interlock Connector

This machine is equipped with a remote interlock connector for connecting to a secondary interlock system; **the welder will not generate a laser pulse unless the remote interlock connector is closed.**

If you are not connecting the remote interlock to an additional interlock system, the shorting connector must be installed on the welder to enable operation of the laser.

- The shorting connector and keys for the key switch are included in the bag inside the welding work chamber.
- For the location of the remote interlock connector, reference **Maintenance: External Fuse Replacement, Rear System Overview & External Connections.**
- To enable operation of the laser, you must insert the shorting connector into the remote interlock connector (located on the controls panel; rear of the machine).
- Manually tighten the connector locking ring clockwise until finger tight.

The remote interlock connector may be used to readily connect the system to a remote interlock circuit, such as an entry door into a specific laser room.

### **To connect the remote interlock to a secondary interlock circuit, the following requirements must be adhered to:**

- Before wiring, the shorting jumper (under the plastic cover of the connector) must be removed.
- The wiring should be routed away from all power cords and should not exceed thirty (30) feet or nine (9) meters) in length.
- The interlock must be a voltage-free, form-A contact (normally open) that is held closed to enable operation of the laser.
- The shorting connection in the connector must be removed and wired to the secondary interlock circuit.
- A licensed professional in compliance and knowledgeable of applicable electrical codes must perform the wiring procedure.

## External Exhaust System

All **class 1** enclosures are equipped with an exhaust connection (2.0” or 50.8 mm) on the rear of the enclosure. We recommend the use of an external exhaust system with the appropriate air filtration (dependent on the type of material being marked, engraved or cut) and an enclosure extraction or vacuum (laser power and enclosure size are taken into account when determining the required “CFM” [200 to 400 CFM is the typical range; application dependent]).



Warning!

**Processing vapors with particulates can be an explosive or fire hazard (depending on the particulate material and concentration). Consult your organization’s internal safety department for details on regulations and concentration levels of fumes with particulates (for your specific material processing) and for requirements set by your local authority for permissibility and safety limits to ensure the lasing equipment is adequate for your application. Lastly, be sure to change the machine’s filters before the change filter indicator is red.**

<b>Inert Gas: Pressure and Flow Regulation</b>		
<b>Operating Pressure (maximum)</b>	<b>Operating Pressure (minimum)</b>	<b>Flow Range (typical)</b>
3.8 bar (59 psi; 0.38 MPa)	0 bar (0 psi; 0 MPa)	10 to 30 CFH

**(Note: To increase cost-savings and offset the expense for inert (argon) gas, the flow rate should be adjusted to the lowest setting possible for achieving the necessary surface finish.)**

## Distilled or Deionized Water

The water reservoir must be filled with distilled or deionized water **before** the machine is turned “on” for the first time; only use distilled or deionized water. The procedure for filling is described in **Service > Initial Filling with Distilled or Deionized Water; section A.**

## Electromagnetic Compatibility

This device meets EMC standards listed in the **Declaration of Conformity** and **Declaration of Compliance.**

## Disassembly and Transport

To prepare the equipment for transport over short distances, you will only need to unplug the power supply and inert gas supply. The distilled or deionized water can remain in the water reservoir, but the tank must be removed from the enclosure.

Before storing the equipment or transporting over longer distances via freight truck, it is recommended that you empty the distilled or deionized water bottle. For this purpose, be sure to reference **Service > Replacing the Distilled or Deionized Water & Changing the Water Reservoir Filter; section C.**

## Preparing for Storage

The equipment must be stored in a clean environment that meets specified storage temperature and humidity requirements. These details can be found in **Introduction > Technical Specifications; section I.**



Caution!

**Do not store or transport the device when temperatures are below 3°C (38°F) and while the distilled or deionized cooling water remains in the tank or laser head, as there is a risk of frost.**

If you anticipate storing or transporting the device at temperatures below 3°C (38°F) or if the equipment will remain unused for longer than a one-month period, the flashlamp chamber (located in the the top optical rail) must be drained. Additionally, you must also drain the water from the machine's hoses and pumps.

**(Note: The procedures for draining the equipment should only be performed by trained service technicians who are affiliated with LaserStar Technologies Corporation® or other authorized personnel who are trained and qualified. Use of unsuitable materials to dry out optical components, including items like tissues and clothing, can scratch surfaces and cause irrevocable damage to these sensitive components.)**

## IV. Operation

### Overview and Fundamentals

This section describes system operations. The ( > ) symbol notes actions that must be carried out by the operator. In most cases, the actions performed by the operator (in any form) will result in reactions from the equipment; these reactions are marked with a (⊗) symbol. The welder can be operated from either the touchscreen display or the joystick controls panel. The buttons on the touchscreen are icons or pictograms used to initiate an action or function when pressed.



**Attention:** Use of controls or adjustments made to performance or procedures other than those specified herein may result in hazardous radiation exposure. If this machine is operated in a manner that has not been approved by the manufacturer, the equipment protections may fail or be compromised. Before operating, be sure that all users have read the information in the section for safety within this manual.

**Attention:** To preserve the touchscreen display and extend the life of this digital device, you should refrain from using inappropriate items (i.e. pencils, pointers, pens, etc.) to press buttons or interact with the digital display. Using these and other unsuitable items can cause the touchscreen display to malfunction, resulting in erratic or faulty operation. This will reduce the lifetime of the touchscreen device and also void the machine's warranty.

Fingers (not finger nails) and the soft stylus pens are the only acceptable instruments that should be used when interacting with the touchscreen display.



**Attention:** To ensure optimum performance, the laser source should be turned on and allowed time to warm up; this warm-up period is important, as it affects final power output. (Note: Some applications will not be sensitive to the output variation.) Details for the warm-up period applicable for this machine can be found in Section 1: Introduction > Technical Specifications.



**Attention:** If a fault occurs, press the "Clear Faults" icon to clear it. The Heartbeat indicator can be selected to display system status indicators, for a full list of fault messages and additional system recovery procedures refer to "VI. Troubleshooting" on page 101 within this manual.



# Initial Operation

Images demonstrating mains and key switch locations are available below

**Mains Power**



**Figure 1a**  
(Switching "ON")

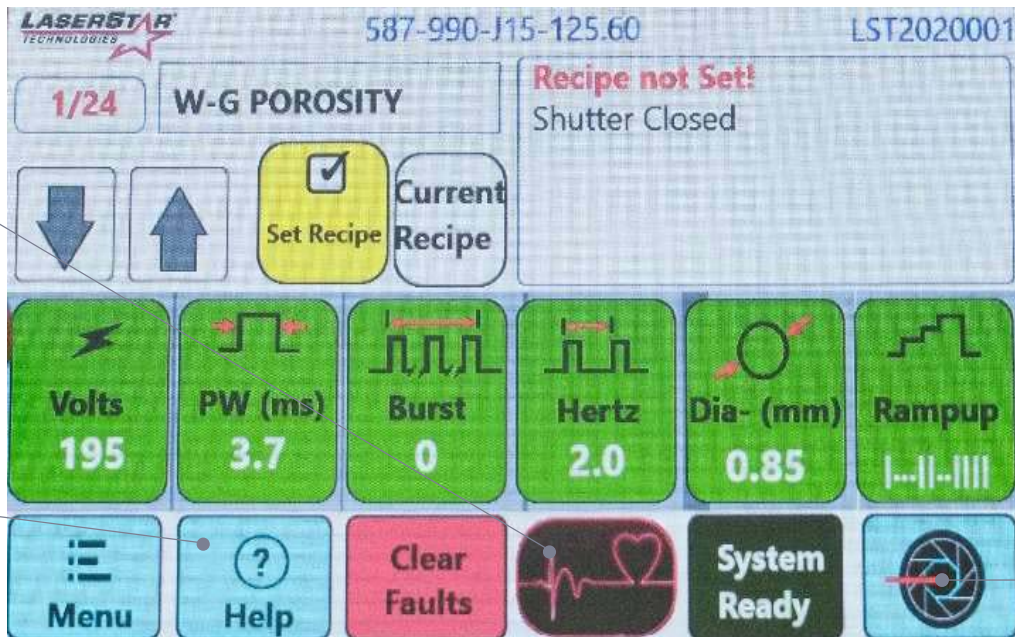
**Key Switch**



**Figure 1b**  
(Switching "ON")

The heart will beat when the system is ready for use.

Shut Down




Safety Shutter Button: (indicates closed: red or open: green)

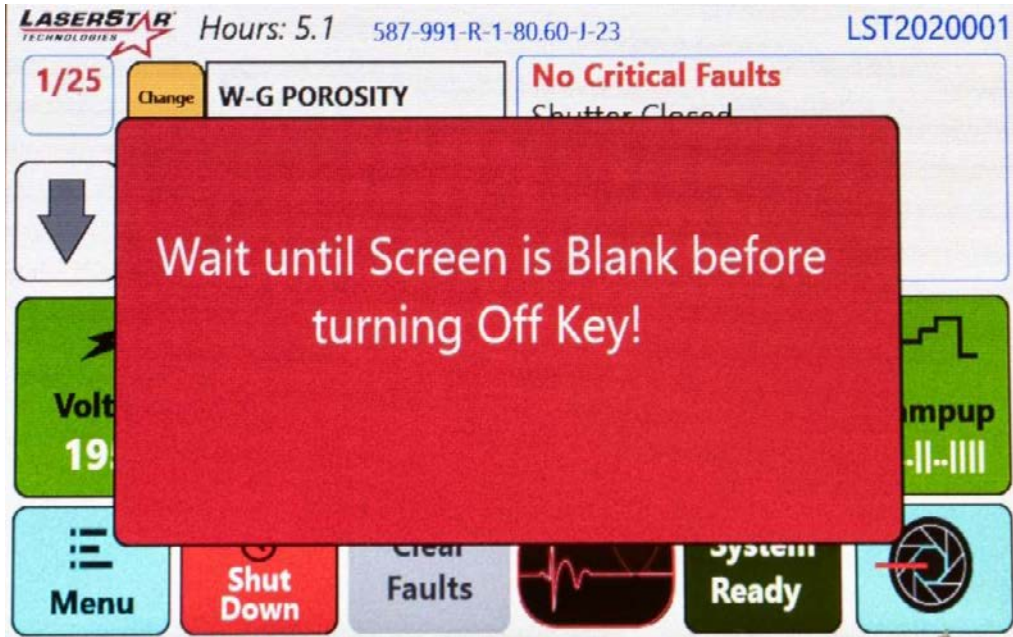
**Figure 2a**  
(Touchscreen Display)

The heart-beat indicator can also be tapped to show fault statuses.

## Switching “On” & Switching “Off” the Welder

Operator Action	System Response
> Make sure the Key switch is in the “OFF” or “0” position ( <b>figure 1</b> ).	(□) Verify.
> Turn the Mains Power Switch to the “ON” or “1” position).	(□) The cooling pump will start. <b>(Note: For optimal laser performance, wait approximately three minutes before turning on the key switch.)</b>
> Turn the key switch to the “ON” or “1” position).	(□) The touchscreen display will turn on. The device carries out a series of self-tests. If any failure occurs, an error message will be indicated in the display (see the section entitled “Status Indications”). The lighting in the welding chamber/area may come on (Note: Depends on dimmer setting.)
> Wait until the self-test (initializing) has been completed.	(□) The heartbeat display button on the touchscreen display will be beat when the system is ready for use.
Press the <b>Safety Shutter Button</b> (located on the touchscreen display; <b>figure 2</b> ). <div style="display: flex; justify-content: space-around; margin-top: 10px;">  </div>	(□) The indicator located within the “safety shutter” button on the touchscreen display will change from closed to open when the shutter is pressed.
> Switching “off” Power Down Procedure	Press the (Shut Down button) on the keypad ( <b>figure 2</b> ). Wait for the screen to turn blank ( <b>figure 2b</b> ). When the screen is blank turn the Key switch to the off position. Now turn off the Main Power (Red Switch) ( <b>figure 1</b> )

## Switching “On” & Switching “Off” the Welder



**Figure 2b**  
(Shut down;  
message 2)

## Flexible Gas Lines



The flexible gas lines, located inside the welding work chamber, are made from plastic and are vulnerable to concentrated heat and prolonged extreme temperatures. Check to be sure the gas lines are not positioned near the chamber lights (most especially the halogen lights), as they are susceptible to melting and could catch fire or drip hot liquified plastic onto the operator's hands and arms or workpieces.

## Adjusting the Stereo Microscope

The stereo microscope is factory-adjusted for operators without vision impairments or abnormalities. Adjustments to the microscope, focus, and cross-hair will likely be necessary for operators who wear (and reliably depend on) glasses or contacts to see.

- Power on the welder using the **mains power switch** followed by the **key switch**.
- Adjust the eyepieces, setting each to the zero (0) mark, and ensuring they're secured and fully inserted into their respective tubes.
- Place a flat object in visual focus as seen through the crosshair-enabled microscope eyepiece. Adjust the other eyepiece as needed to bring the object into focus.
- Rotate the upper portion of the eyepiece to orient the crosshair in the desired position.
- Adjust the distance between both eyepieces so that the visual fields for both overlap (with eyes relaxed, observe the sample workpiece); a single rounded visual field should be present.

After finalizing all adjustments, the sample workpiece and cross-hair should appear sharply in focus while looking through each of the eyepieces simultaneously.

## Mounting the Stereo Microscope

When completing the steps below for microscope mounting and optical alignment, be sure to reference the optical alignment diagram on the next page.

1. Place the stereo microscope into the mounting bracket. **(figure 4)**
2. Secure the microscope to the body of the welder by tightening the two (2) mounting screws. The mounting screws are located between the center, left, and right adjustment screws (see the diagram on the next page for details and a visual reference).
3. **If using a Lynx Scope:** Plug the microscope into the power input (located on the left-hand side of the welder; opposite the **mains power switch**).

## Optical Alignment

1. Using an adjustable lab jack (tabletop scissor-lift platform) or equivalent device, bring the steel plate into focus.
2. Adjust the parameters, as follows: 260V, 1.0ms, 0.0Hz, 0.5mm.
3. Fire a single laser pulse onto the steel plate; be sure to leave the plate in place.
4. Using the three (3) adjustment screws (refer to the diagram on the next page for placement), align the laser pulse position within the center of the cross-hair. **Caution: Be careful not to remove or overtighten the adjustment screws.**
5. Fire an additional single laser pulse onto the steel plate, testing to ensure that all adjustments for alignment are correct.

**(Note: Be sure to re-check the alignment periodically; adjustments may also need to be made for workpieces that differ in size or structure.)**

# Optical Alignment Diagram

**NOTES:**

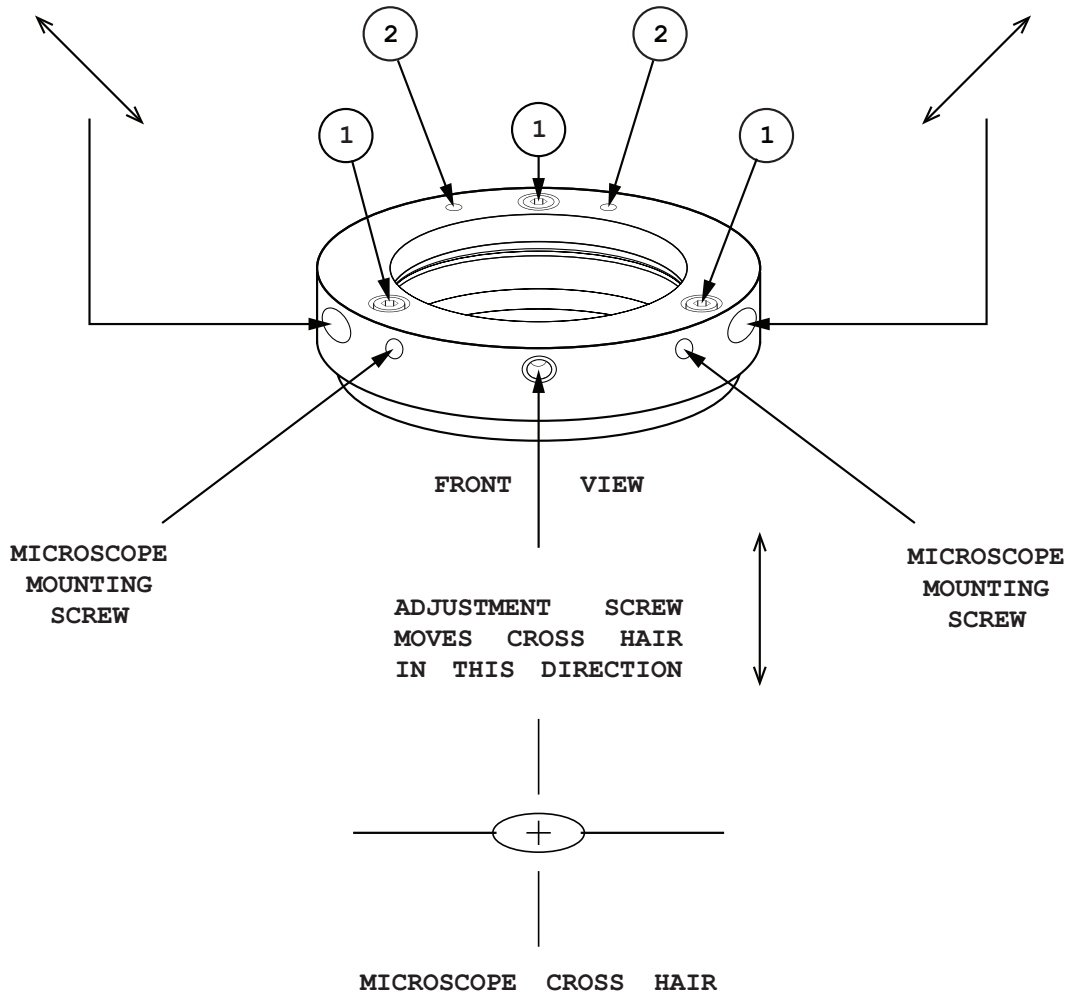
DO NOT REMOVE OR LOOSEN SCREWS LABELED. (1)

TO REMOVE MOUNTING BRACKET, LOOSEN CAPTURED SCREWS IN HOLES LABELED. (2)

(SCREWS WILL LOOSEN, BUT WILL NOT COME OUT).

ADJUSTMENT SCREW  
MOVES CROSS HAIR  
IN THIS DIRECTION

ADJUSTMENT SCREW  
MOVES CROSS HAIR  
IN THIS DIRECTION



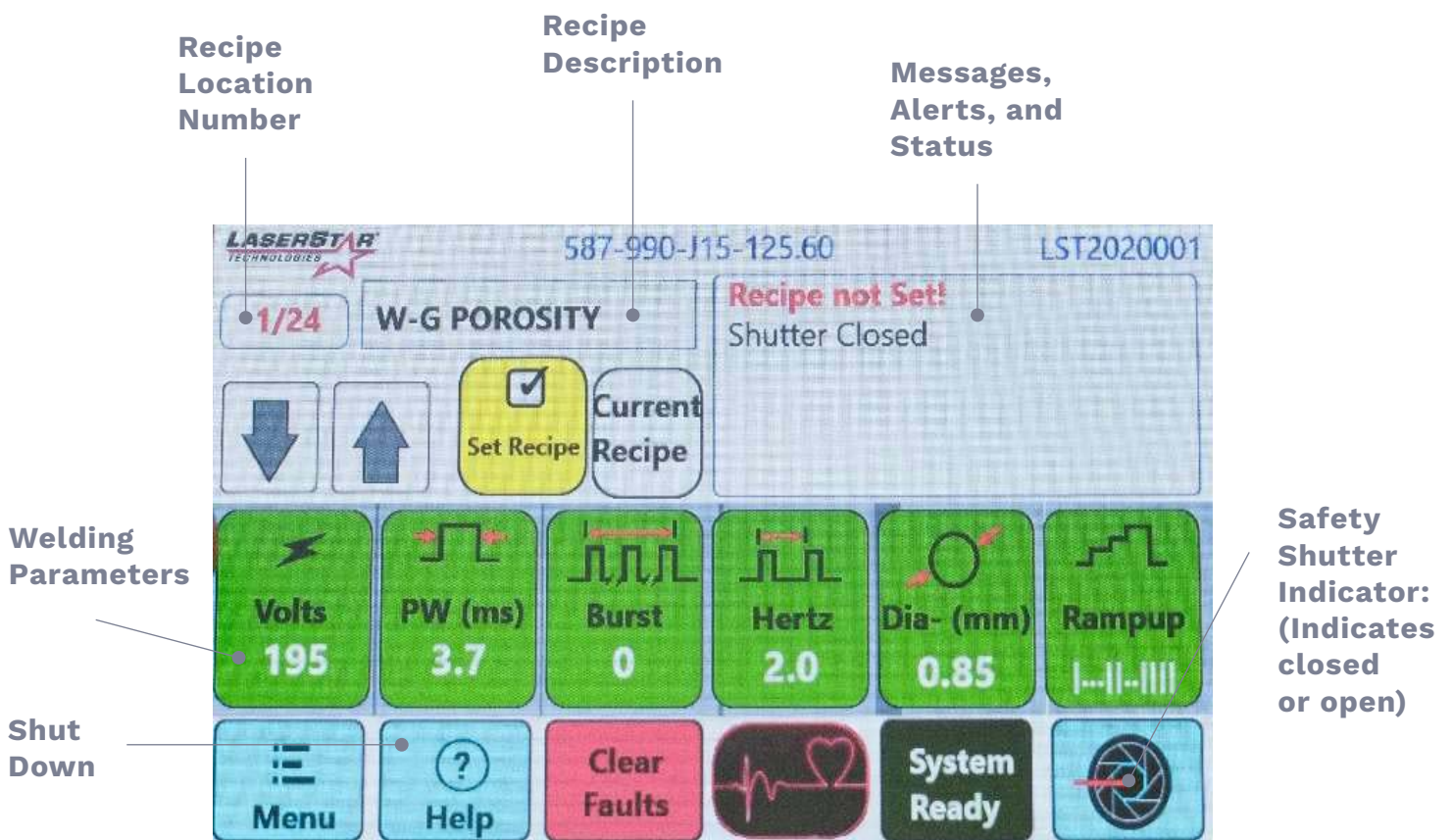
**Figure 4**  
(Optical Alignment  
Diagram)

## Setting Operating Parameters

Selecting operating parameters can be achieved using either the touchscreen display or joystick control. **(Note: The safety shutter button, in conjunction with the joystick, allow for specialized functions, which are defined in more detail later in this manual.)**

## Touchscreen Display Operation

When pressing buttons on the touchscreen display, be sure to press directly in the center; off-center button pressing can result in unintended or undesirable actions.



**Figure 5**  
(Touchscreen  
Display)

## Messaging & Touchscreen Display Operation (continued)

<b>Touchscreen Display Commands</b>	
<b>Buttons &amp; Indicators</b>	<b>System Response</b>
System Fault: Red	The system is not ready to operate; the safety shutter will not open.
System Ready: Green	The system is ready to operate; the safety shutter can be opened.
Safety Shutter: Closed	When the icon for the <b>Safety Shutter button</b> is closed, the shutter is closed. Press the <b>Safety Shutter button</b> to open.
Safety Shutter: Open	When the icon for the <b>Safety Shutter button</b> is open, the shutter is open. Press the <b>Safety Shutter button</b> to close.
Changing a Recipe Location Number (see <b>figures 6 – 10</b> that follow)	<p>Press the <b>Recipe Location button</b> to change the recipe location number (<b>figure 5</b>).</p> <p>A number box will appear.</p> <p>Press the number and a numeric keypad will appear.</p> <p>Press Clear to clear the old location number.</p> <p>A number box will appear.</p> <p>Type in the desired memory location number; press OK and then press Done.</p> <p>Press the yellow (Set Recipe) button to load the values into the weld parameters.</p> <p>Loaded values will appear green.</p> <p><b>(Note: Memory recipe locations may be loaded with factory defaults.)</b></p>

**Messaging & Touchscreen  
Display Operation Continued on Next Page**

## Messaging & Touchscreen Display Operation (continued)

<b>Touchscreen Display Commands</b>	
<b>Buttons &amp; Indicators</b>	<b>System Response</b>
<p>&gt; Recipe Location Description Set Recipe button Figure 9 &amp; 10</p>	<p><input type="checkbox"/> Weld Recipe Descriptions:</p> <p>Yellow (Set Recipe) button indicates the weld parameters are from this memory location; the parameters will be grey.</p> <p>Push button to Set Recipe. Green (Set Recipe) button indicates the recipe has been set into the parameters; the parameters will be green.</p>
<p>&gt; Welding Parameters:</p> <ul style="list-style-type: none"> <li>• Volts</li> <li>• PW (ms)</li> <li>• Hertz, Burst or Pulse Suppression (optional and model specific)</li> </ul> <p>Figures 11, 12, 13, 14</p>	<p><input type="checkbox"/> Current Welding Parameters:</p> <p>Volts- Press this button to change the value. A window will open with the current value, and up down arrow keys. Use the up / down arrows to change the value and then press Done. When the window with the current value is open, you may also press the number value, a numeric keypad will come up. You can then type in the desired value and press OK, then press Done.</p> <p>PW (ms)- Press this button to change the value. A window will open with the current value, and up down arrow keys. Use the up / down arrows to change the value and then press Done. When the window with the current value is open, you may also press the number value, a numeric keypad will come up. You can then type in the desired value and press OK, then press Done.</p> <p>Hertz- Press this button to change the value. A window will open with the current value, and up down arrow keys. Use the Up or Down arrows to change the value and then press Done. When the window with the current value is open, you may also press the number value, a numeric keypad will come up. You can then type in the desired value and press OK, then press Done.</p>

**Messaging & Touchscreen  
Display Operation Continued on Next Page**

## Messaging & Touchscreen Display Operation (continued)

<b>Touchscreen Display Commands</b>	
<b>Buttons &amp; Indicators</b>	<b>System Response</b>
<p>&gt; Welding Parameters:</p> <ul style="list-style-type: none"> <li>• Hertz , Burst or Pulse Suppression (optional and model specific)</li> <li>• DIA (mm)</li> <li>• Shape (P<sup>3</sup>)</li> </ul> <p>Figures 11, 12, 13, 14</p>	<p>(□) Current Welding Parameters (continued):</p> <p>Burst- Press this button to change the value. A window will appear with the current value, and up down arrow keys. Use the Up and Down arrows to change the value and then press Done. When the window with the current value is open, you may also press the number value, a numeric keypad will come up. You can then type in the desired value and press OK, then press Done.</p> <p>DIA (mm)- Press this button to change the value. A window will appear with the current value, and up down arrow keys. Use the Up or Down arrows to change the value and then press Done. When the window with the current value is open, you may also press the number value, a numeric keypad will come up. You can then type in the desired value and press OK, then press Done.</p> <p>SHAPE-Press this button to change the P<sup>3</sup> shape. A window will open with the current Shape, and up down arrow keys. Use the Up or Down arrows to change the P<sup>3</sup> shape and then press OK.</p> <p><b>(Note: Once the value of each setting has been changed from the set recipe value, the button will turn from Green to Red (FIGURE 14). If the (Set Recipe) button is pressed again, all the settings will go back the that recipe's values and all buttons will turn green once again.)</b></p>


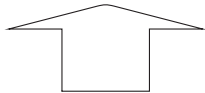
**Messaging & Touchscreen  
Display Operation Continued on Next Page**

## Messaging & Touchscreen Display Operation (continued)

<b>Touchscreen Display Commands</b>	
<b>Buttons &amp; Indicators</b>	<b>System Response</b>
<p>&gt; Messages FIGURE 5 Figure 15</p>	<p>(□) Displays the laser status which includes-Critical Faults, shutter status and info, etc. A critical fault will appear in the message box and the heart will be broken indicating the laser cannot be used until the fault is cleared.</p>
<p>&gt; Saving &amp; naming a Recipe Figure 16-21</p>	<p>(□) Features:</p> <ul style="list-style-type: none"> <li>• Press the recipe description button, an alphanumeric keypad will appear.</li> <li>• Press the Clear button to clear the old recipe name; type in a name for the new recipe.</li> <li>• Press OK; this will store the new name.</li> <li>• Adjust the parameters to the desired setting; press the yellow (Save) button. A window will appear that asks: “Are you sure you want to save (with the name of your setting?) Button options: Save or Cancel. If you wish to save, press the Save button. The new setting will receive a new number location.</li> <li>• To delete a recipe first select the recipe you wish to delete. Press the Save button. Press the Delete button. (Figure 21)</li> </ul> <p><b>Attention: All information in this memory location will be lost.</b></p> <p><b>(Note: The parameters and description for factory default memory locations will also be cleared by this CLEAR button, but can be restored by going to the Main Screen / Menu / Restore Def Memory / LST.)</b></p>

**Messaging & Touchscreen  
Display Operation Continued on Next Page**

## Messaging & Touchscreen Display Operation (continued)

<b>Touchscreen Display Commands</b>	
<b>Buttons &amp; Indicators</b>	<b>System Response</b>
> Menu	<input type="checkbox"/> Pressing this button opens a PIN Number screen. Press the PIN Number box and a numeric keypad will appear. Enter your PIN Number. Press OK, Press Done. (Figure 22)
> Menu Selection	<input type="checkbox"/> You are now in the Menu Selection screen. (Figure 23)
> (Down / DN) 	<input type="checkbox"/> Pressing this button will decrease the selected weld parameter values/shape; reduces memory location number; and selects Menu function (>).
> (Up) 	<input type="checkbox"/> Pressing this button will increase the selected weld parameter values/shape; increases memory location number; and selects Menu function (>).
Save	<input type="checkbox"/> Pressing this button will store the displayed weld parameters into memory location number displayed in the upper left corner.
> Menu Selection Screen: <ul style="list-style-type: none"> <li>• Create Custom Profile</li> <li>• Configuration</li> <li>• Register Status</li> <li>• Password</li> <li>• System Tests</li> <li>• Help</li> <li>• Factory Reset</li> <li>• Main Menu</li> </ul>	<input type="checkbox"/> Create Custom Profile: This screen allows the operator to create a custom profile. <ul style="list-style-type: none"> <li>• Press the (Create Profile) Figure 25.</li> <li>• The segment active on/off is divided into 12 segments. On the active row, you may change a segment by touching the active box either on (green) or off (red). (Figure 27)</li> <li>• When you are finished, press the done button, and then press Save; a Ramp Name box will display. (Figure 28)</li> <li>• If you wish to name your new profile, press the name in the box and an alphanumeric keypad will display. (Figure 29).</li> </ul>

## Messaging & Touchscreen Display Operation Continued on Next Page

## Messaging & Touchscreen Display Operation (continued)

<b>Touchscreen Display Commands</b>	
<b>Buttons &amp; Indicators</b>	<b>System Response</b>
<p>&gt; Menu Selection Screen (continued):</p> <ul style="list-style-type: none"> <li>• Create Custom Profile</li> <li>• Configuration</li> <li>• Register Status</li> <li>• Password</li> <li>• System Tests</li> <li>• Utility Menu</li> <li>• Help</li> <li>• Factory Reset</li> <li>• Main Menu</li> </ul>	<p>(☐) Type the new name and press Done. (Figure 30).</p> <p><b>Configuration:</b> For LST factory internal use only.</p> <p><b>Register Status:</b> For LST factory internal use only.</p> <p>Password:</p> <ul style="list-style-type: none"> <li>• To change your password, Press (Password) in the Menu screen. (Figure 25)</li> <li>• Screen to enter PIN Number will appear. (Figure 31)</li> <li>• Press the white box, the alphanumeric keypad will appear. (Figure 32) Enter your existing password and press OK. The Screen to enter PIN Number will appear again. (Figure 31) Press Done.</li> <li>• Password Setup appears. (Figure 33) Press Enter New PIN box. The alphanumeric keypad will appear again. (Figure 32) Type in the new password and press OK.</li> <li>• The screen to enter PIN Number will appear yet again, (Figure 31) Press Done, then press Return. The Password is now changed.</li> </ul>
	<p><b>System Tests:</b> For LST Service internal use only.</p> <p>Help: Press the Help Button, information for contacting LaserStar Technologies Corporation® Service Department appears. (Figure 34)</p>

**Messaging & Touchscreen  
Display Operation Continued on Next Page**

## Messaging & Touchscreen Display Operation (continued)

<b>Touchscreen Display Commands</b>	
<b>Buttons &amp; Indicators</b>	<b>System Response</b>
	<p><b>System Tests:</b></p> <p>Help:</p> <ul style="list-style-type: none"> <li>• Press the Help Button, information for contacting LaserStar Technologies Corporation® Service Department appears. (Figure 34)</li> <li>• Press View, a Help Menu appears. (Figure 35) The sub-menu choices are, Startup, Message, Lamp Change, Laser Settings, Recipe Features and Menu Items. Pressing any one of these submenus will start a video presentation. (Figure 36) To enlarge the video, press the arrows in the lower right-hand corner. (Figure 37)</li> </ul> <p><b>Note: Video shown is Lamp Change.</b></p> <p>Factory Reset:</p> <p>Pressing this button will take you to two choices, Reset and Cancel. Figure 38</p> <ul style="list-style-type: none"> <li>• Pressing reset will set the laser back to factory settings.</li> <li>• Pressing Cancel will bring you back to the Menu screen.</li> </ul> <p><b>Note: Once the laser is Factory Reset, all programed settings will be lost.</b></p> <p>Main Menu:</p> <p>Takes you back to the main operating screen. (Figure 5)</p>

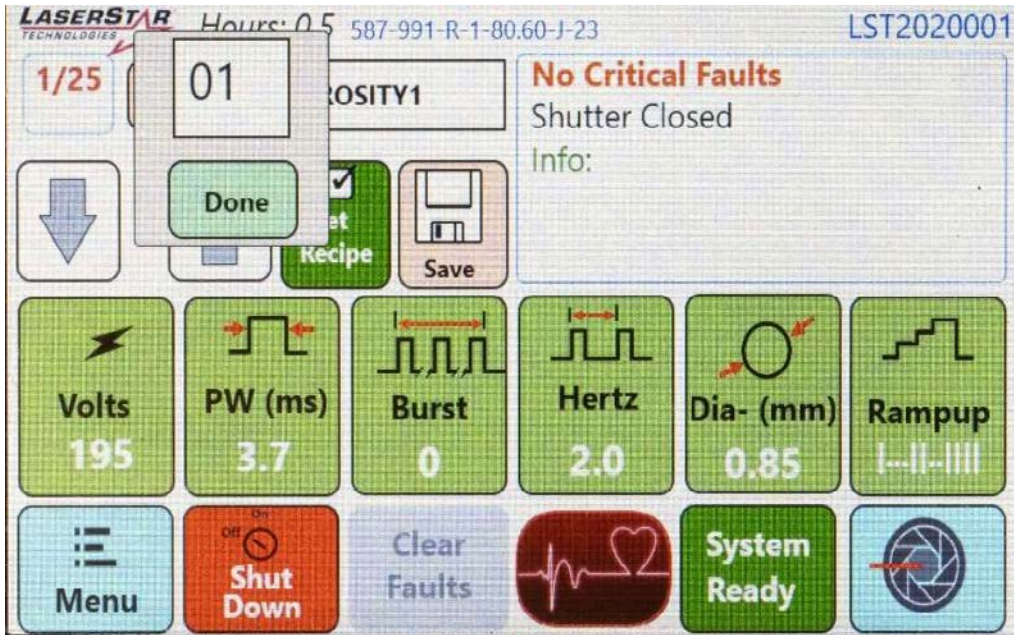
**Messaging & Touchscreen  
Display Operation Continued on Next Page**

## Messaging & Touchscreen Display Operation (continued)

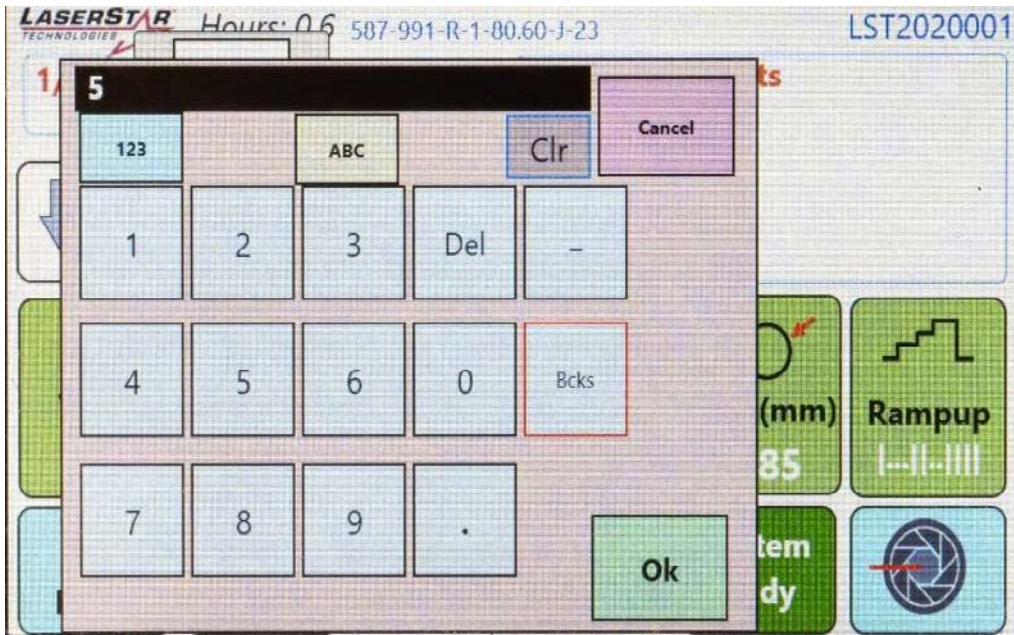
<b>Touchscreen Display Commands</b>	
<b>Buttons &amp; Indicators</b>	<b>System Response</b>
	<p><b>Utility Menu:</b> For LST Service internal use only.</p> <p>Phase 2 Features: Pre-weld Gas Post-weld Gas Pulse Count Hours On: Pulse Total: Fault Lists: Energy Usage: Volt Adj: Beam Ex Offset: Sleep:</p> <p>Figures 7 &amp; 16</p>
<p>Alphanumeric Keypad</p> <ul style="list-style-type: none"> <li>• I23</li> <li>• ABC</li> <li>• Cancel</li> <li>• Del</li> <li>• Clr</li> <li>• OK</li> <li>• Bcks</li> <li>• –</li> </ul>	<p>I23: Press this button to bring up the numeric keypad.</p> <p>ABC: Press this button to bring up the numeric keypad.</p> <p>Cancel: Pressing this button will return you to the main operating screen.</p> <p>Del: Press this button to delete the last character.</p> <p>Clr: Pressing this button will clear the memory location description entirely.</p> <p>OK: Press this button to save memory location description.</p> <p>Bcks: Press this button to delete the last character.</p> <p>– Press this to add a hyphen</p>

## Messaging & Touchscreen Display Operation Continued on Next Page

## Messaging & Touchscreen Display Operation (continued)

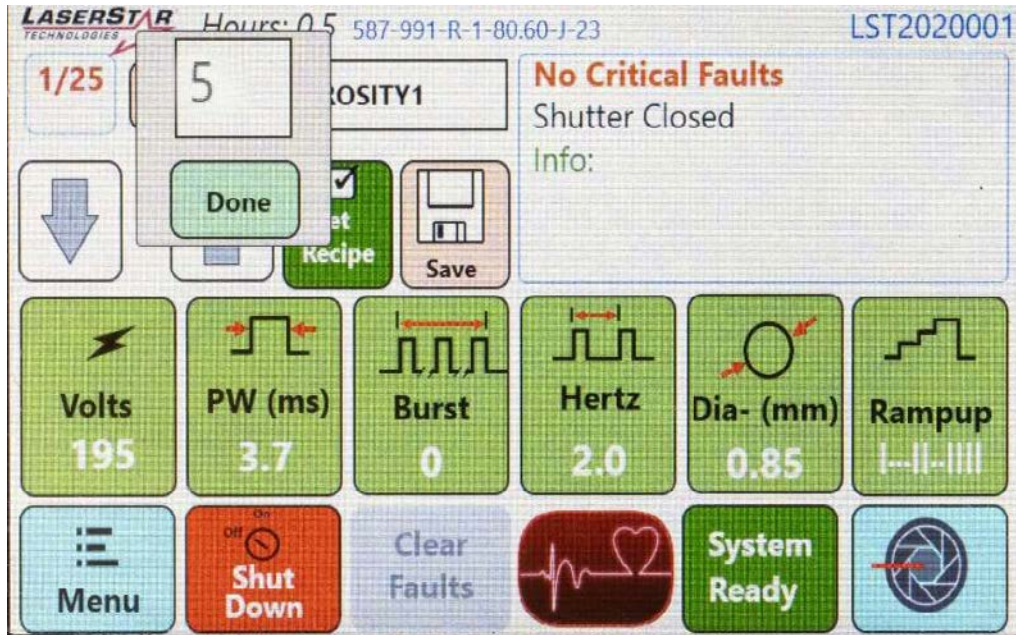


**Figure 6**  
(Recipe Location  
Number)

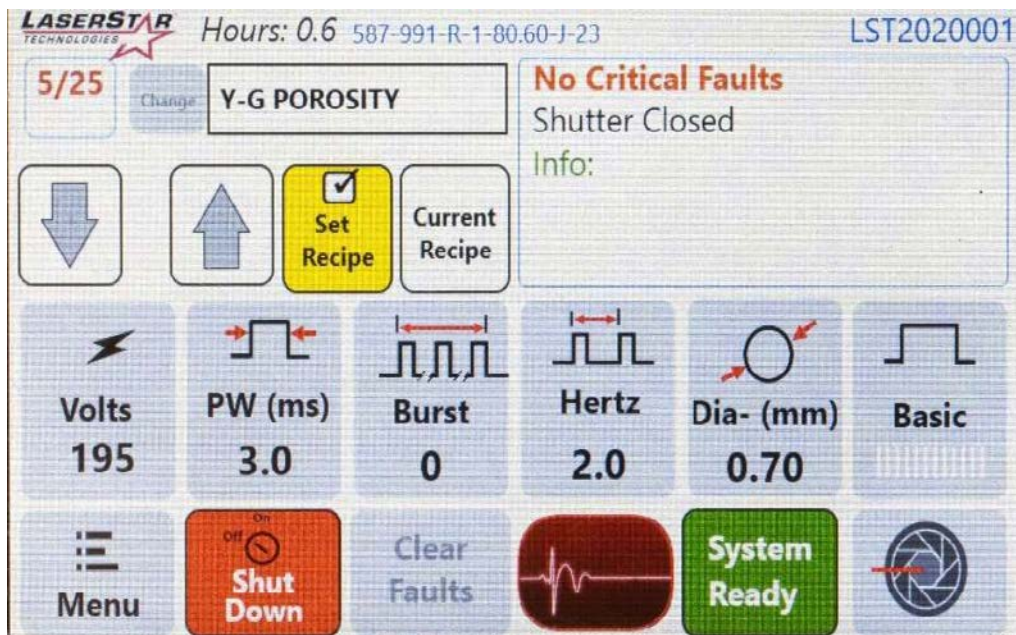


**Figure 7**  
(Numeric Keypad [Type  
Desired Recipe Number])

## Messaging & Touchscreen Display Operation (continued)



**Figure 8**  
(Done Button)



**Figure 9**  
(Set Recipe)

## Messaging & Touchscreen Display Operation (continued)

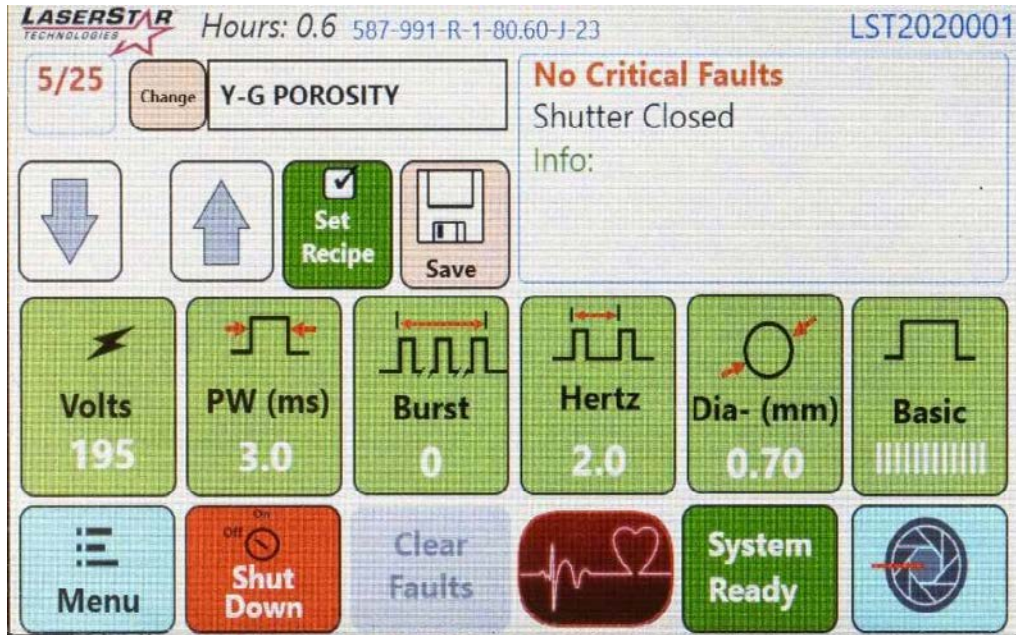


Figure 10  
(Recipe Set)

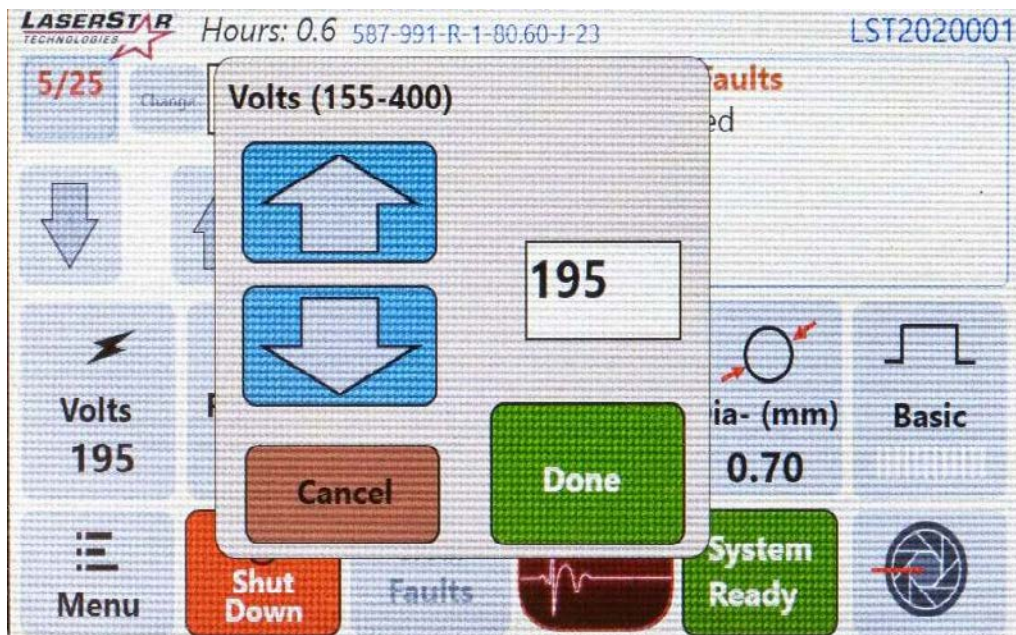
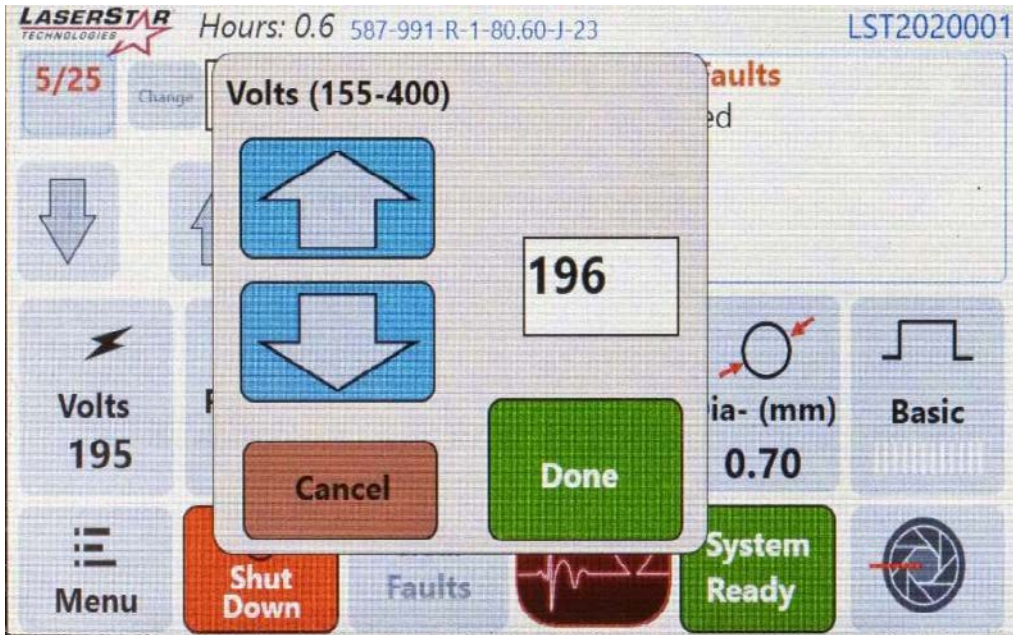
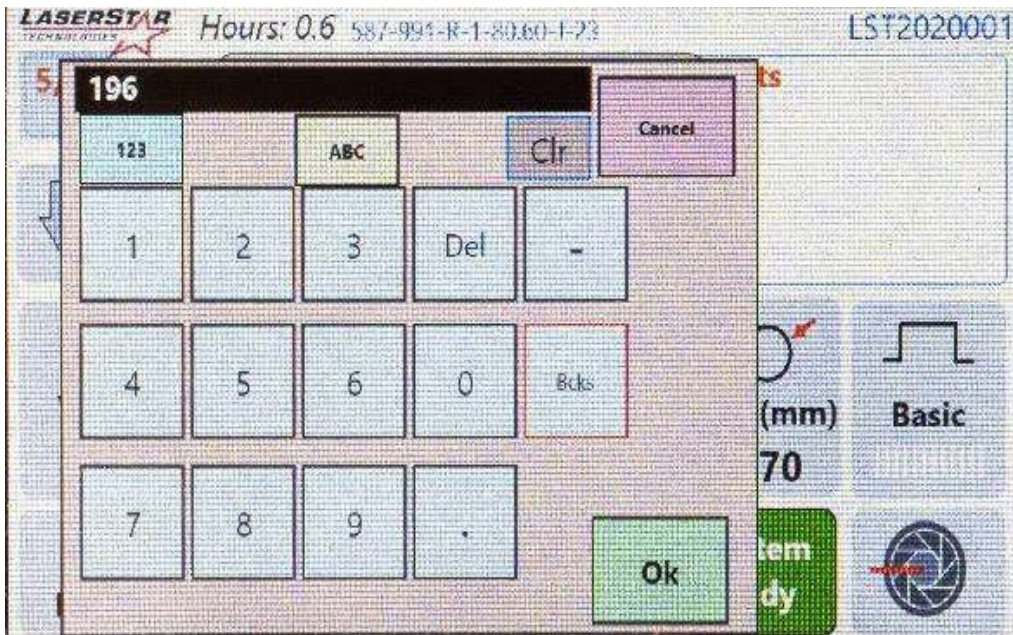


Figure 11  
(Arrow Keypad)

## Messaging & Touchscreen Display Operation (continued)

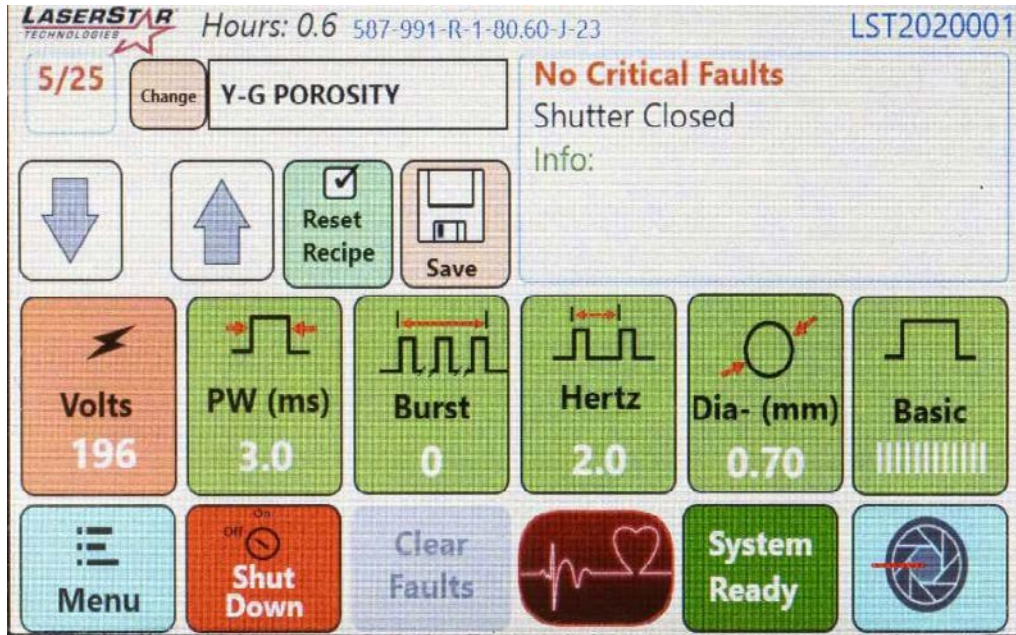


**Figure 12**  
(Change Value [Enter Value  
Using Arrow Keypad; Press Done  
to Confirm])

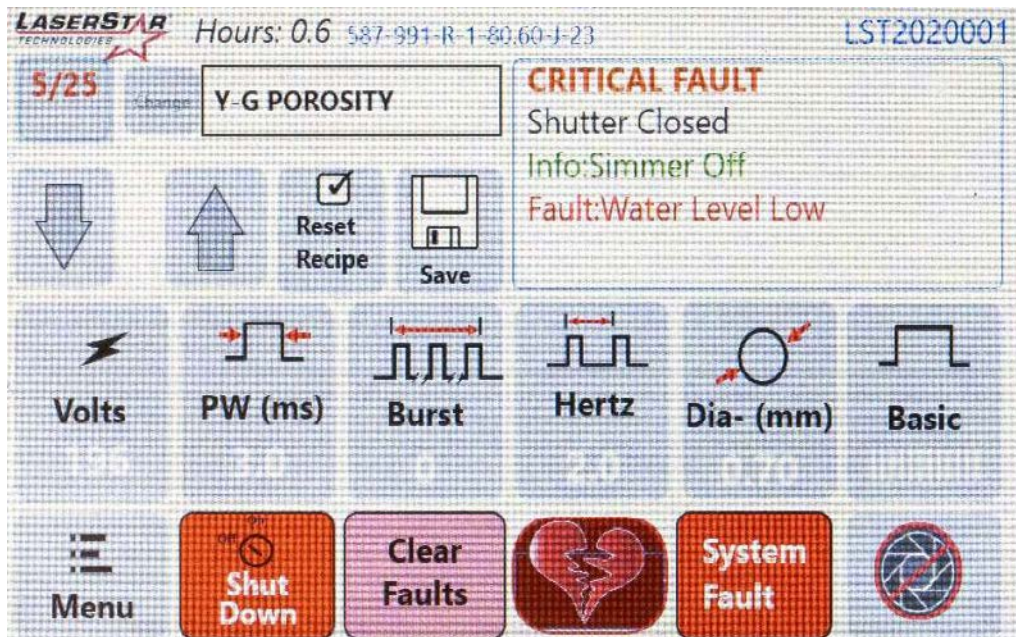


**Figure 13**  
(Change Value [Enter Value  
Using Numeric Keypad; Press Ok  
to Confirm])

## Messaging & Touchscreen Display Operation (continued)

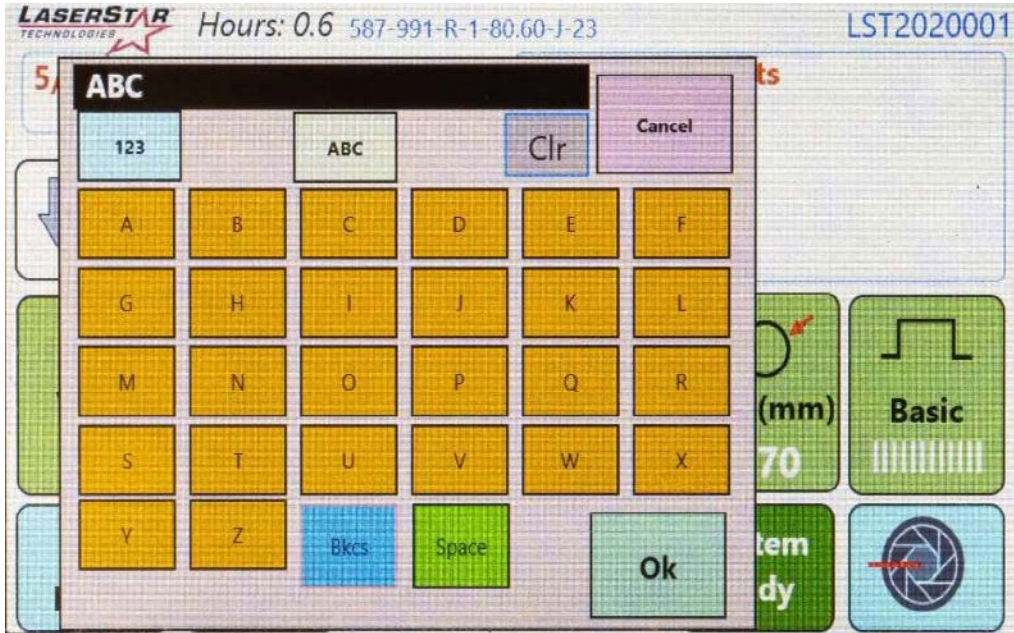


**Figure 14**  
(Changed Parameter)

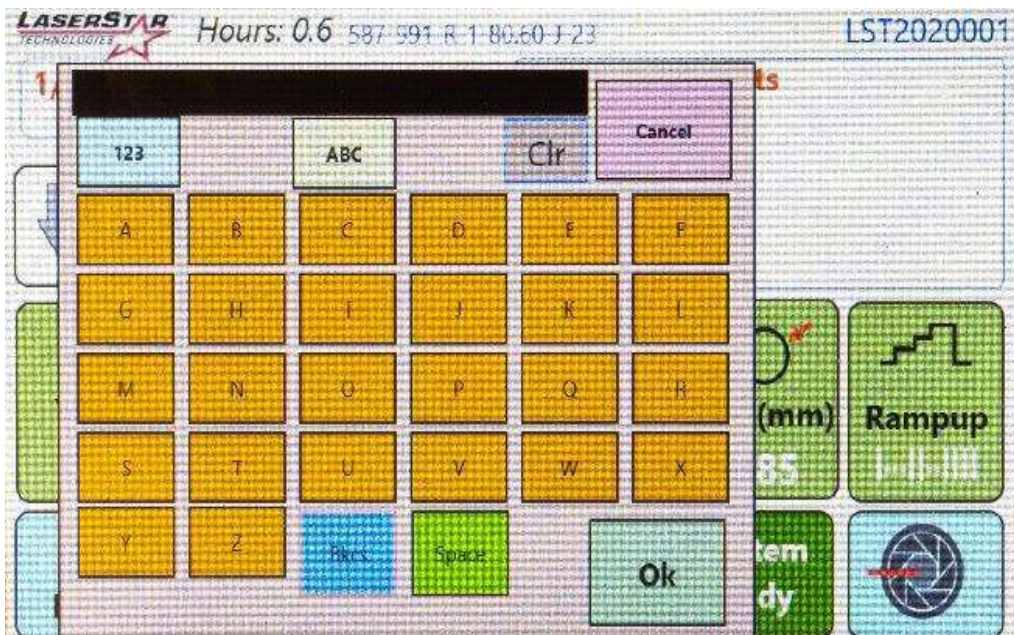


**Figure 15**  
(Critical Fault)

## Messaging & Touchscreen Display Operation (continued)

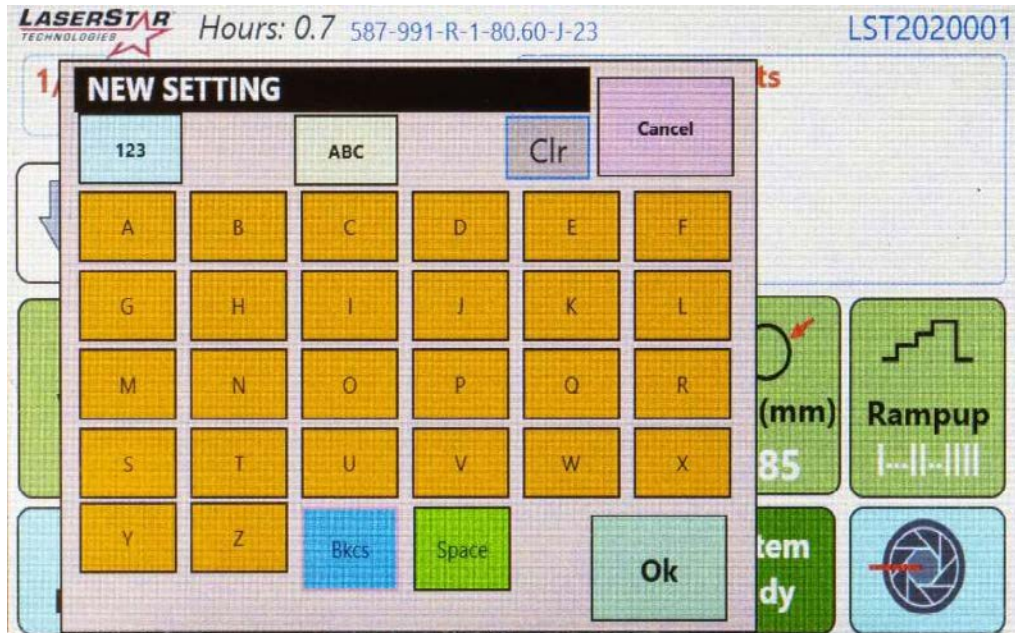


**Figure 16**  
(Alphanumeric Keypad)

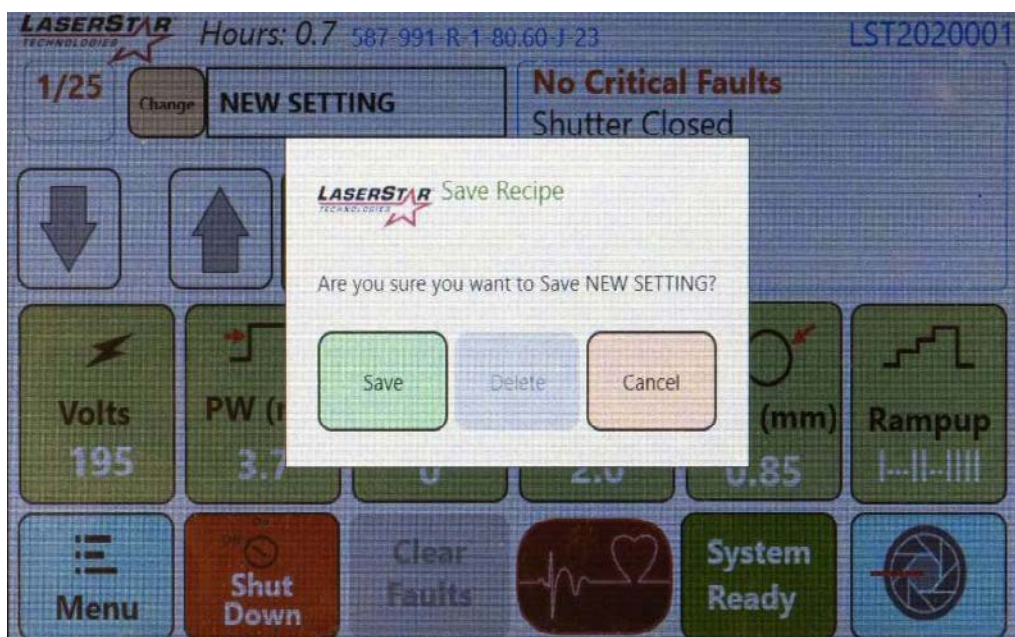


**Figure 17**  
(Clear Name [Use Clr Button;  
Left of Cancel Button])

## Messaging & Touchscreen Display Operation (continued)

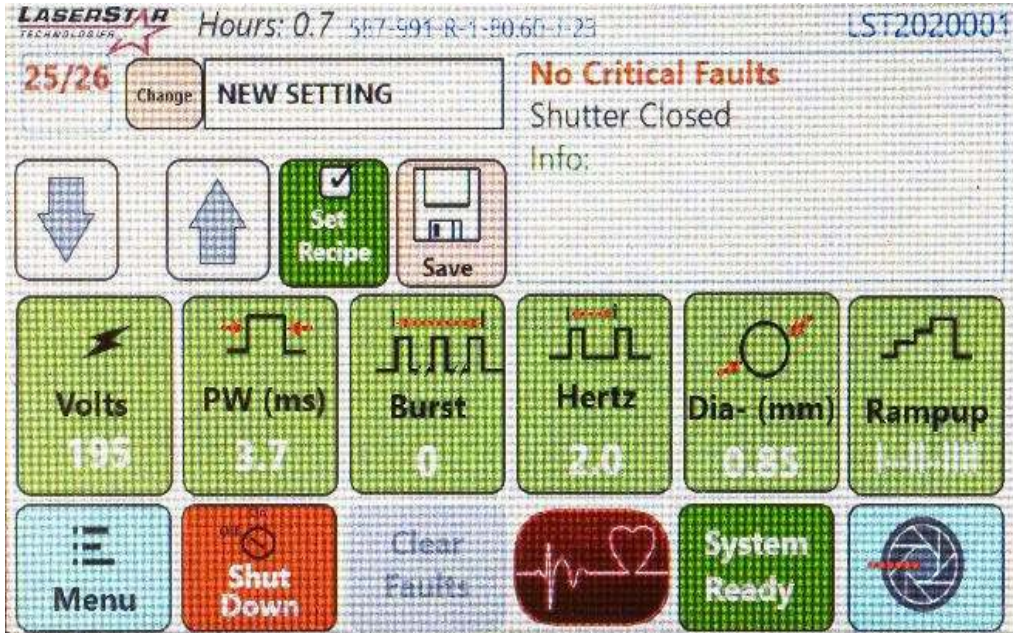


**Figure 18**  
(Input New Name [Enter Value Using Alphanumeric Keypad; Press Ok to Confirm])

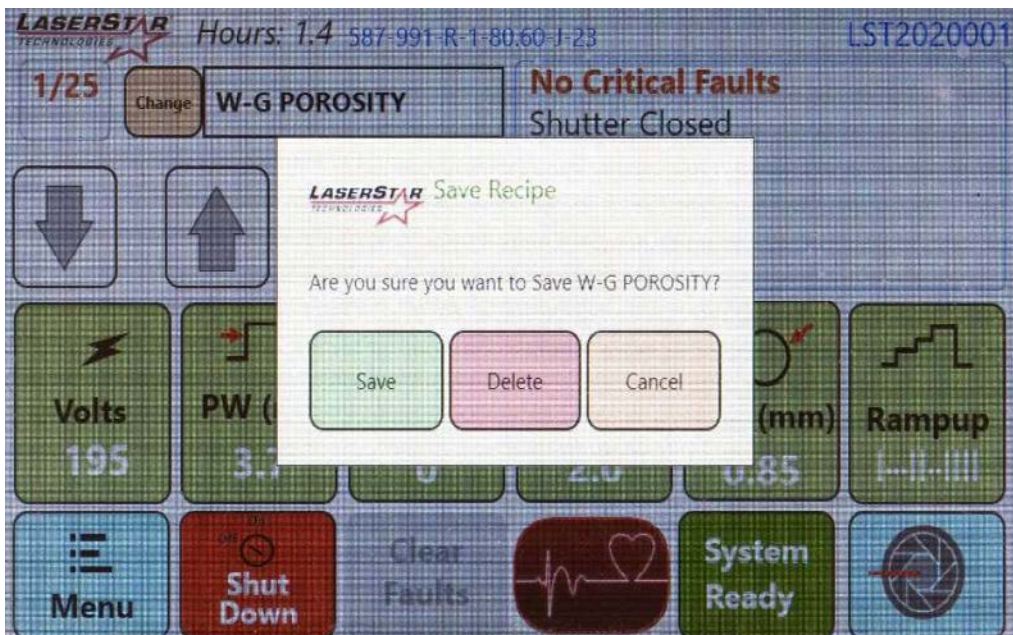


**Figure 19**  
(Save New Recipe [Press Save to Confirm])

## Messaging & Touchscreen Display Operation (continued)

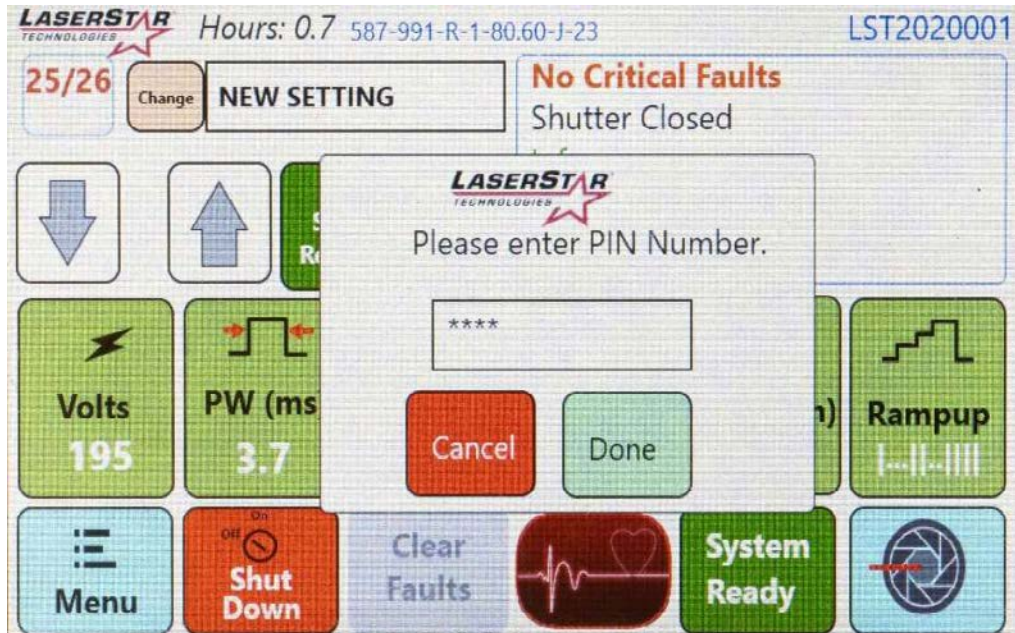


**Figure 20**  
(Set New Recipe [Saved  
Parameter Keys are Green])

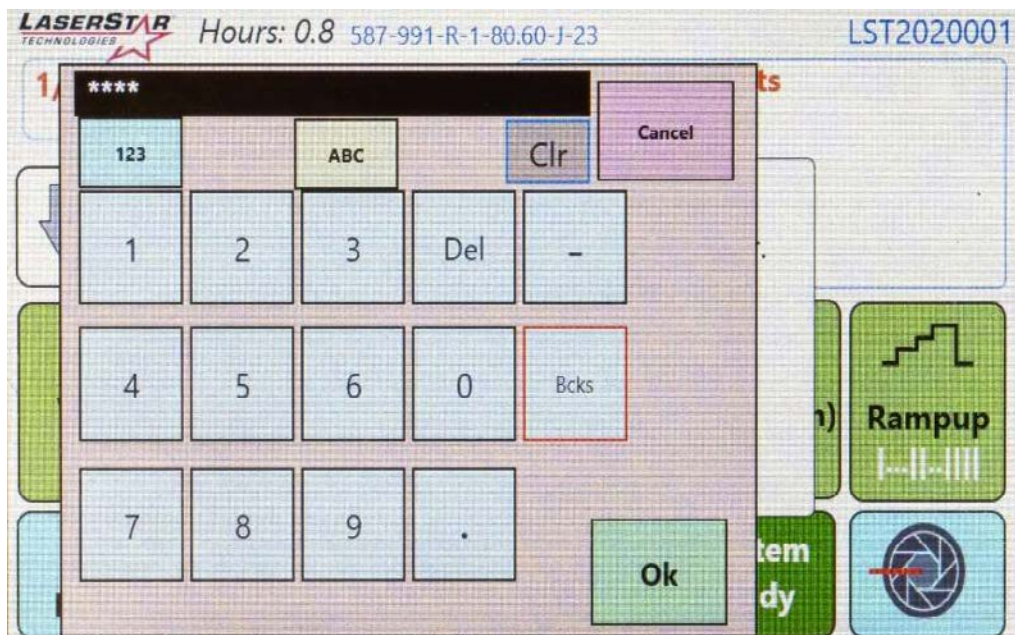


**Figure 21**  
(Press Delete [Clears  
Recipe Setting])

## Messaging & Touchscreen Display Operation (continued)

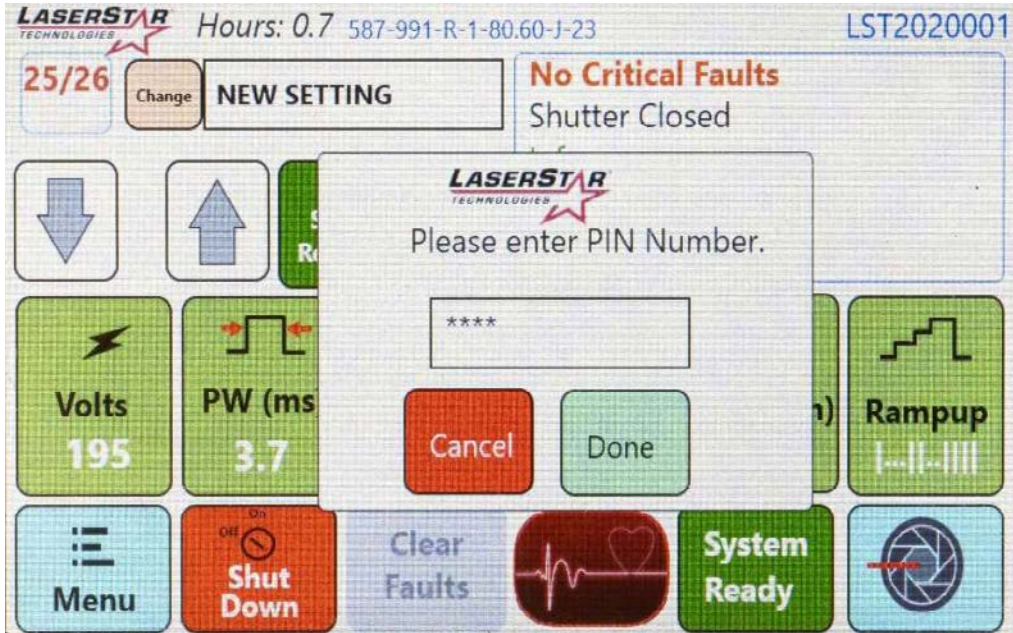


**Figure 22**  
(Input PIN Number [Press  
Done to Confirm])

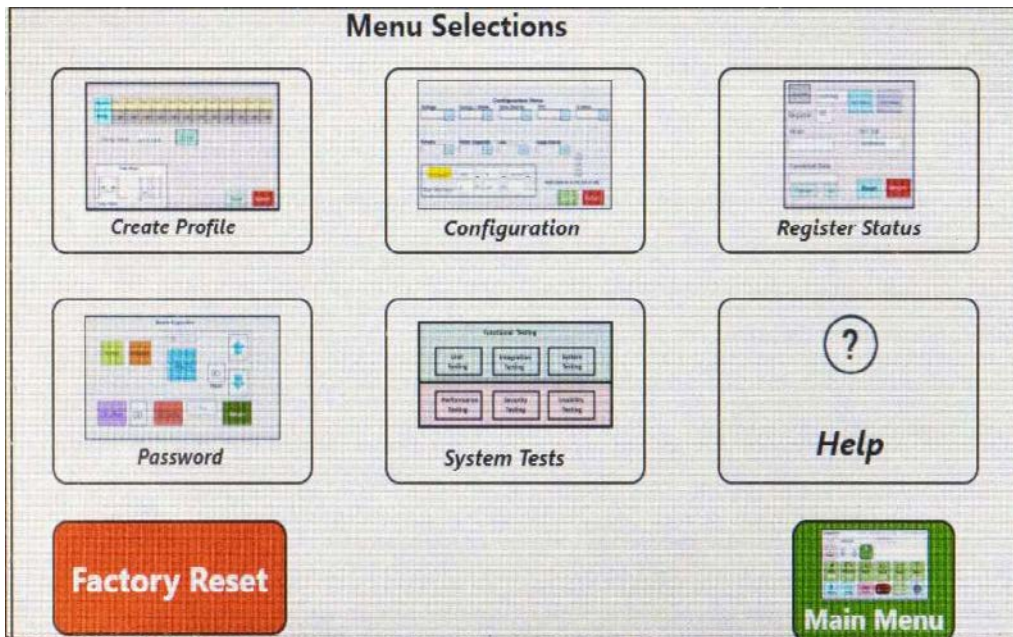


**Figure 23**  
(Input PIN Number [Enter  
Value Using Numeric Keypad;  
Press Ok to Confirm])

## Messaging & Touchscreen Display Operation (continued)

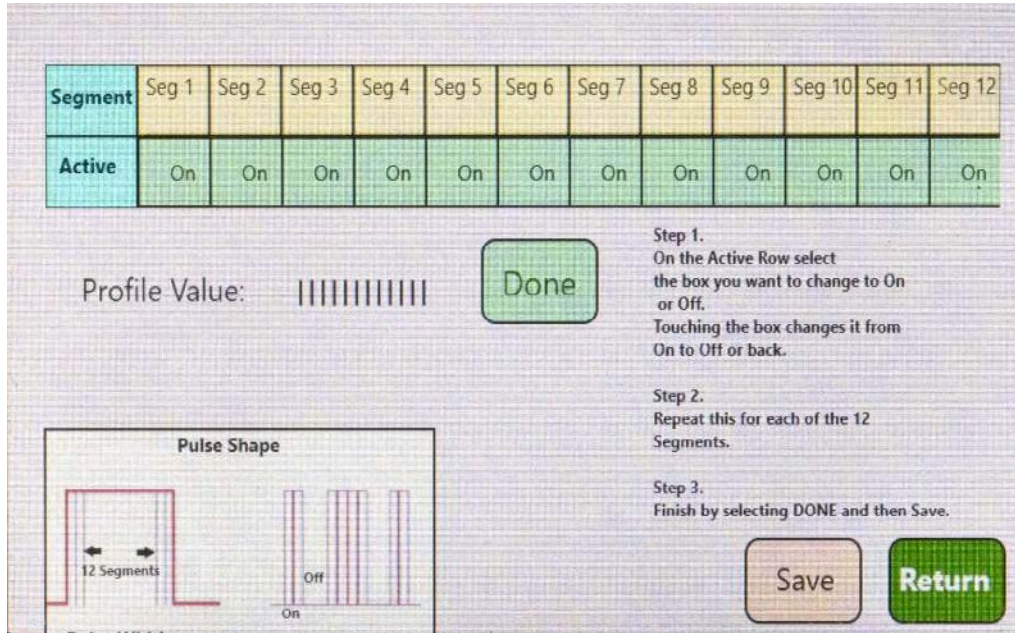


**Figure 24**  
(Input PIN Number [Press  
Done to Confirm])

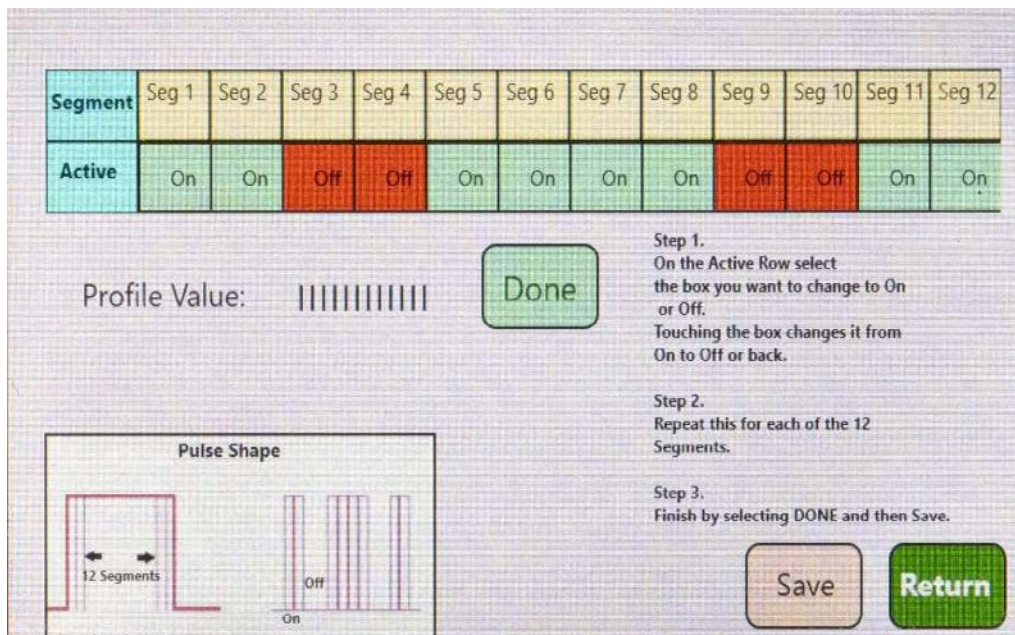


**Figure 25**  
(Menu Selection Screen)

## Messaging & Touchscreen Display Operation (continued)

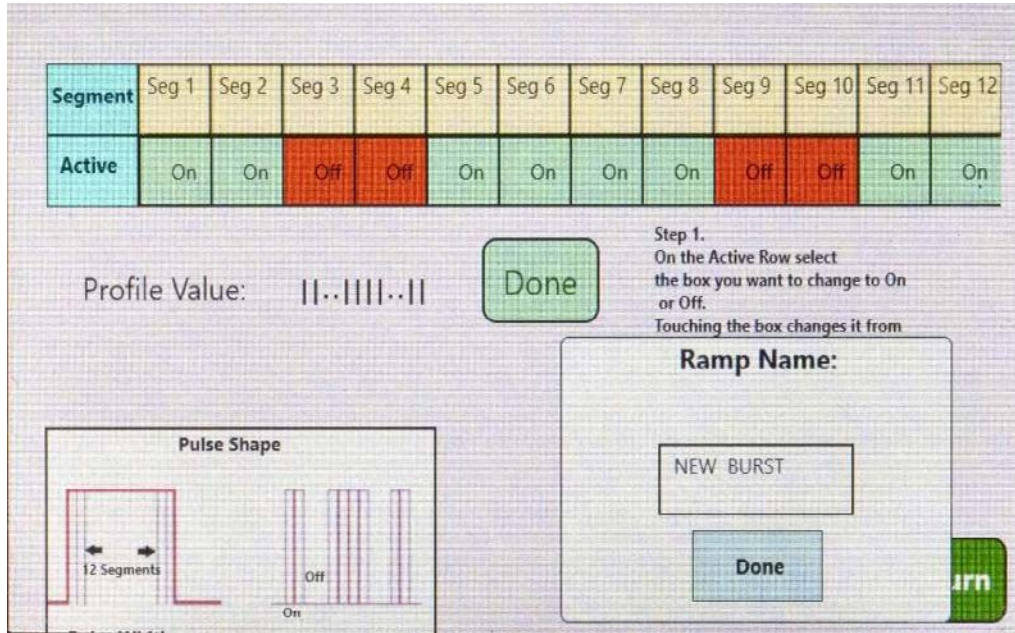


**Figure 26**  
(Create Profile [Press Done; Press Save to Confirm Settings])

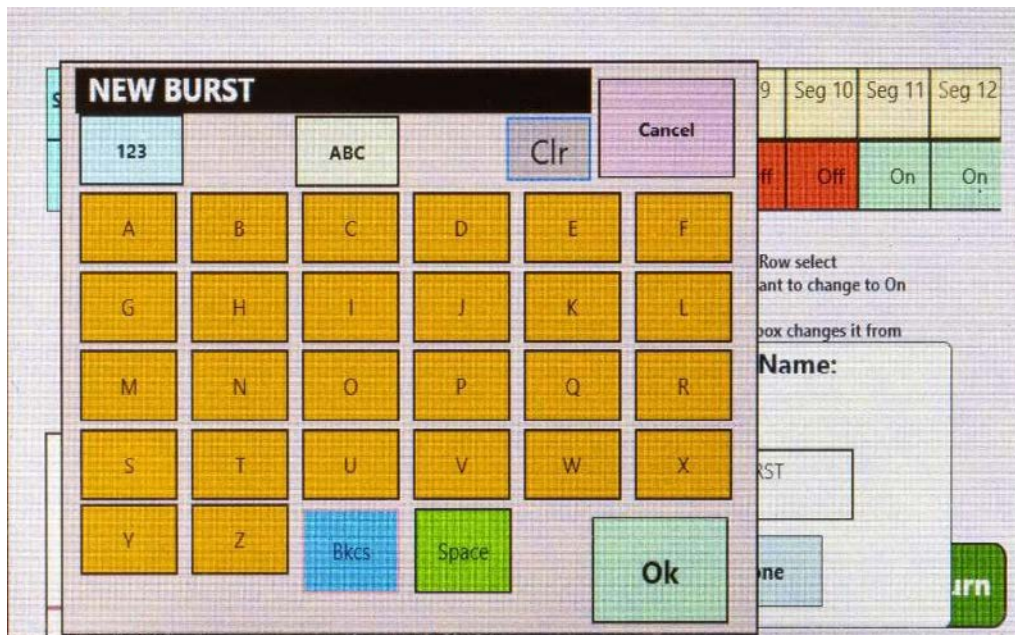


**Figure 27**  
(Select Active [Choose "On" or "Off"])

## Messaging & Touchscreen Display Operation (continued)

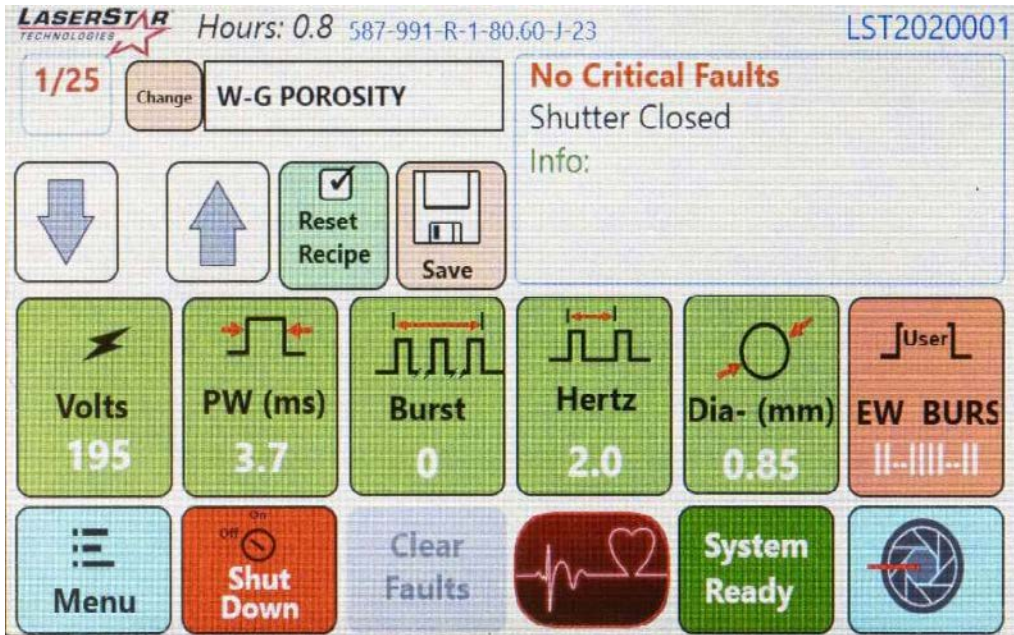


**Figure 28**  
(Ramp Name)

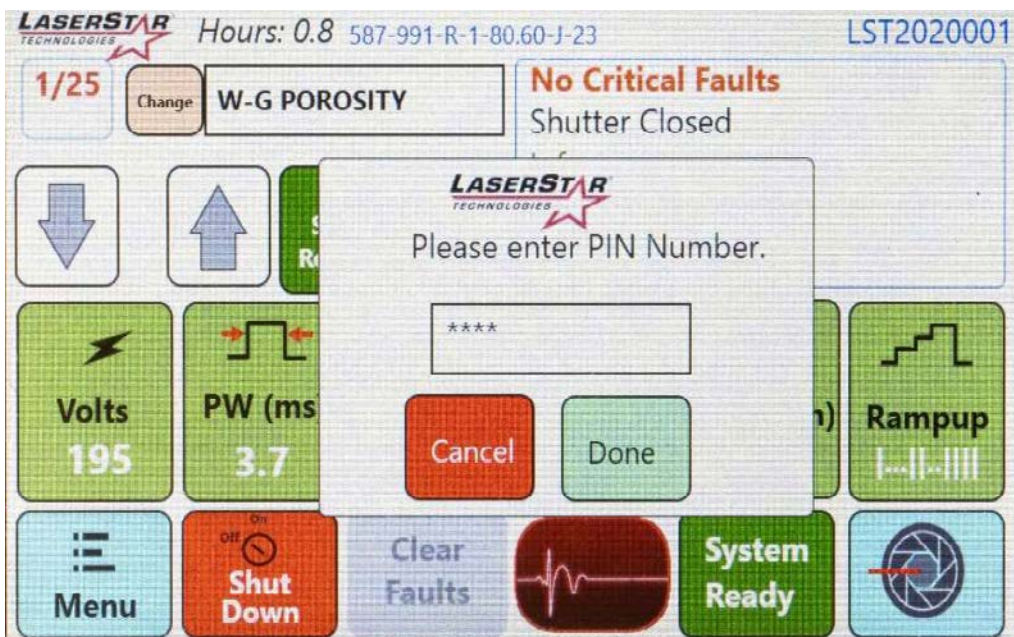


**Figure 29**  
(Alphanumeric Keypad)

## Messaging & Touchscreen Display Operation (continued)

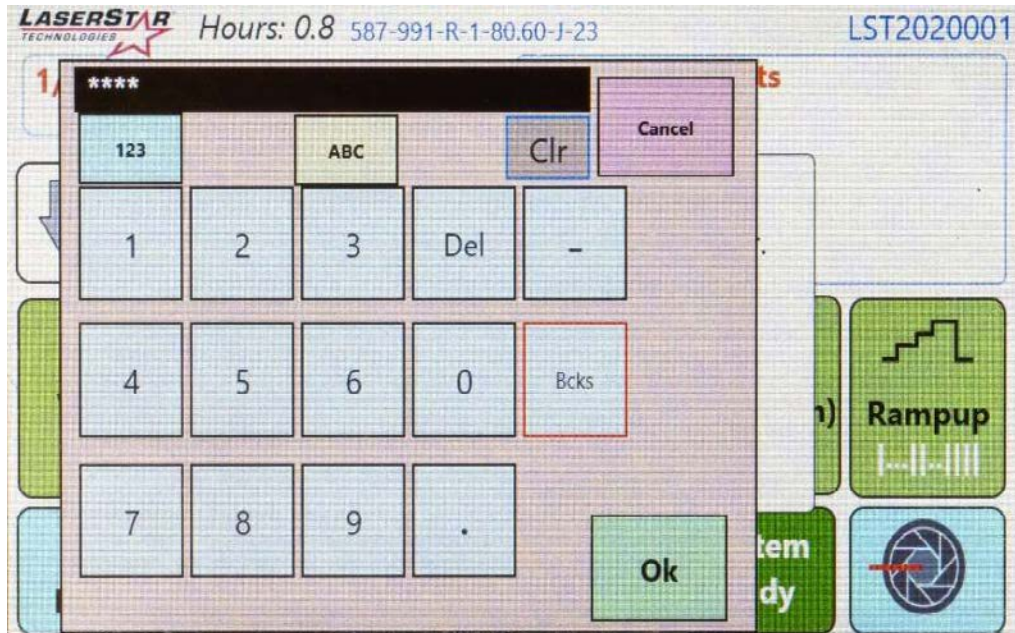


**Figure 30**  
(Custom Profile)



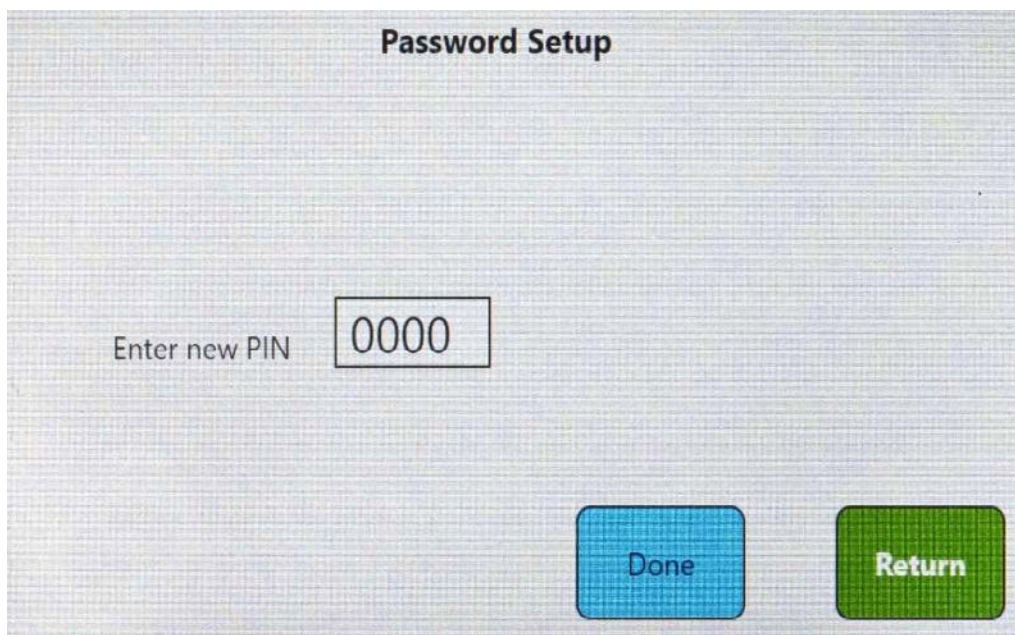
**Figure 31**  
(Input PIN Number [Press  
Done to Confirm])

## Messaging & Touchscreen Display Operation (continued)



**Figure 32**

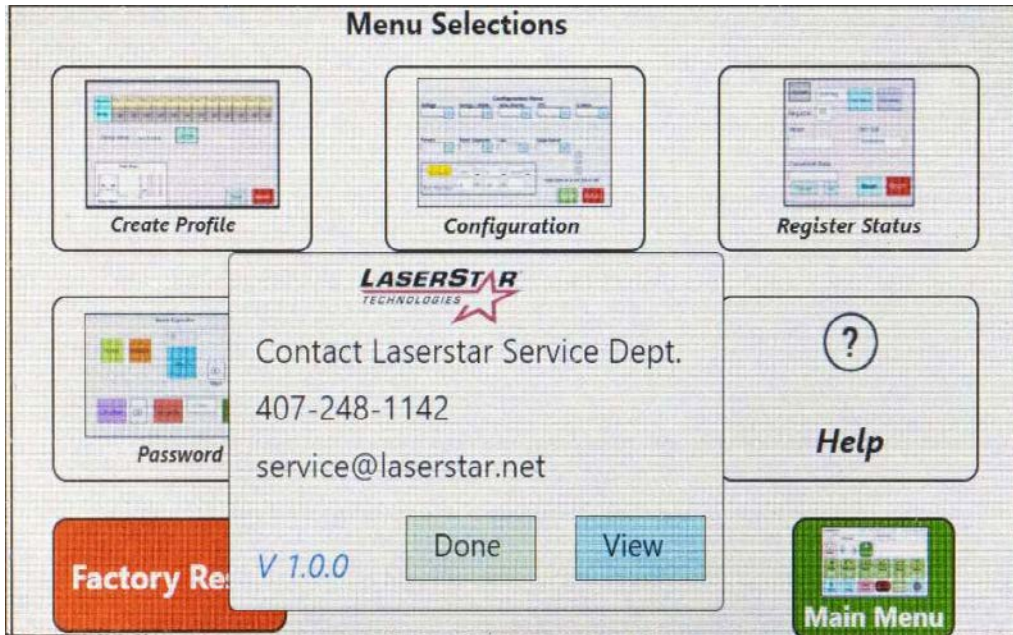
(Input PIN Number [Enter  
Value Using Numeric Keypad;  
Press Ok to Confirm])



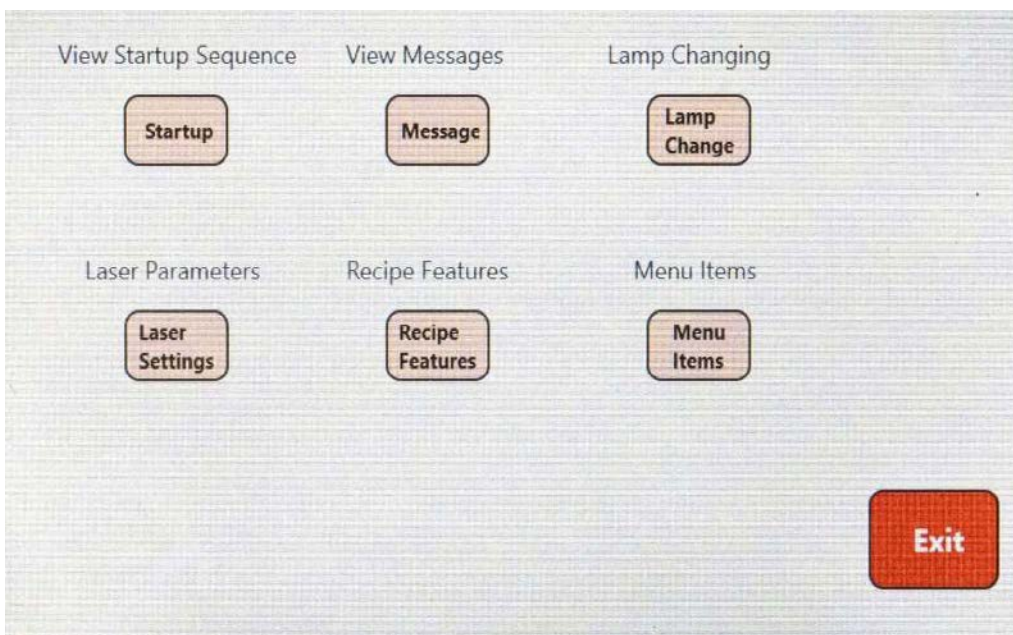
**Figure 33**

(New Password Setup [Press  
Done to Confirm])

## Messaging & Touchscreen Display Operation (continued)

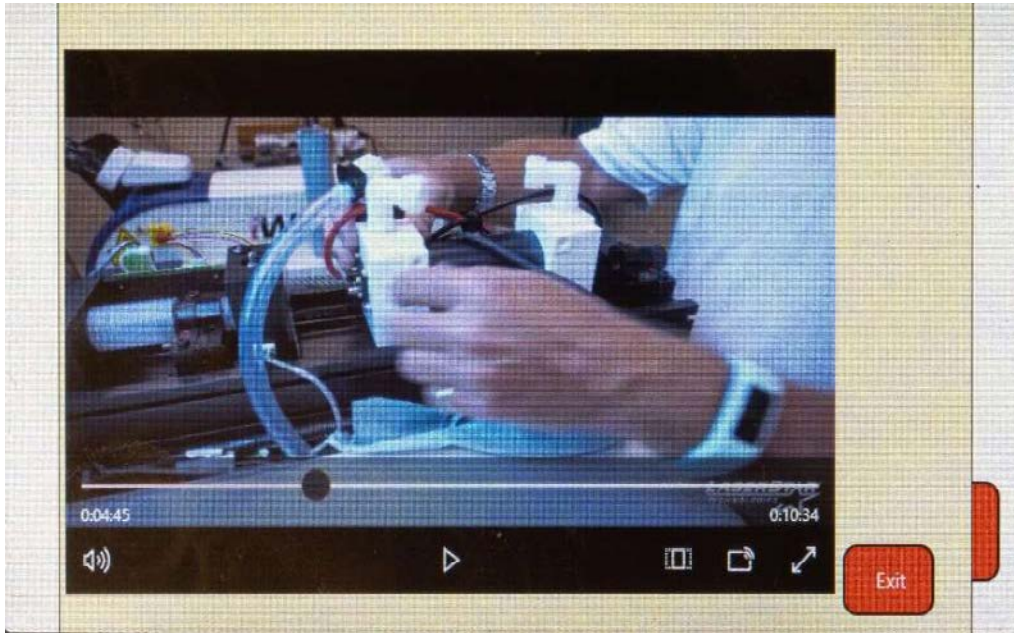


**Figure 34**  
(LaserStar Service  
Contacts)

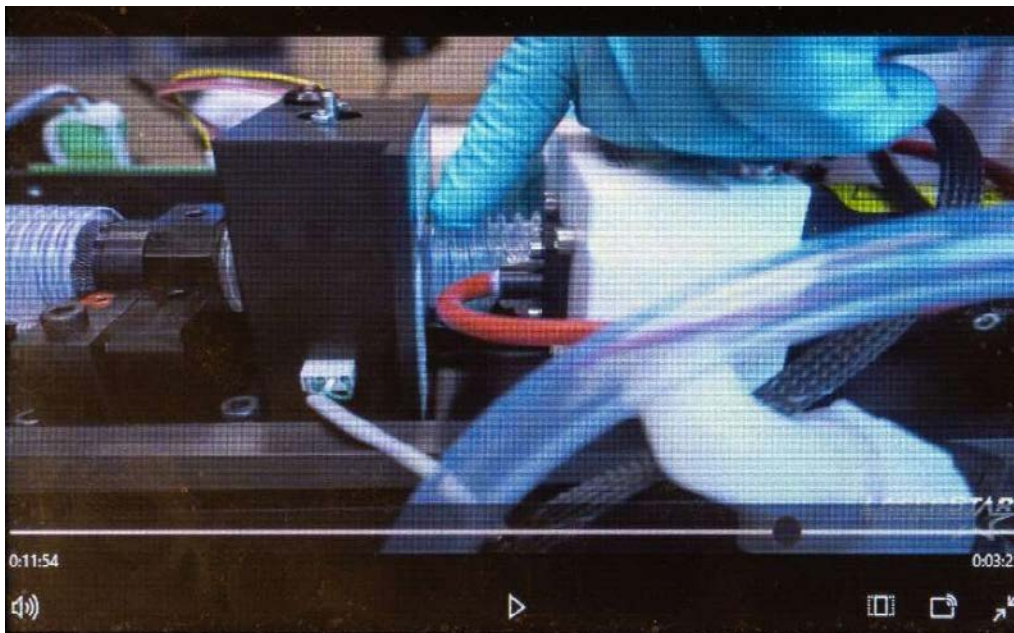


**Figure 35**  
(Help Topics  
[Secondary Menu])

## Messaging & Touchscreen Display Operation (continued)

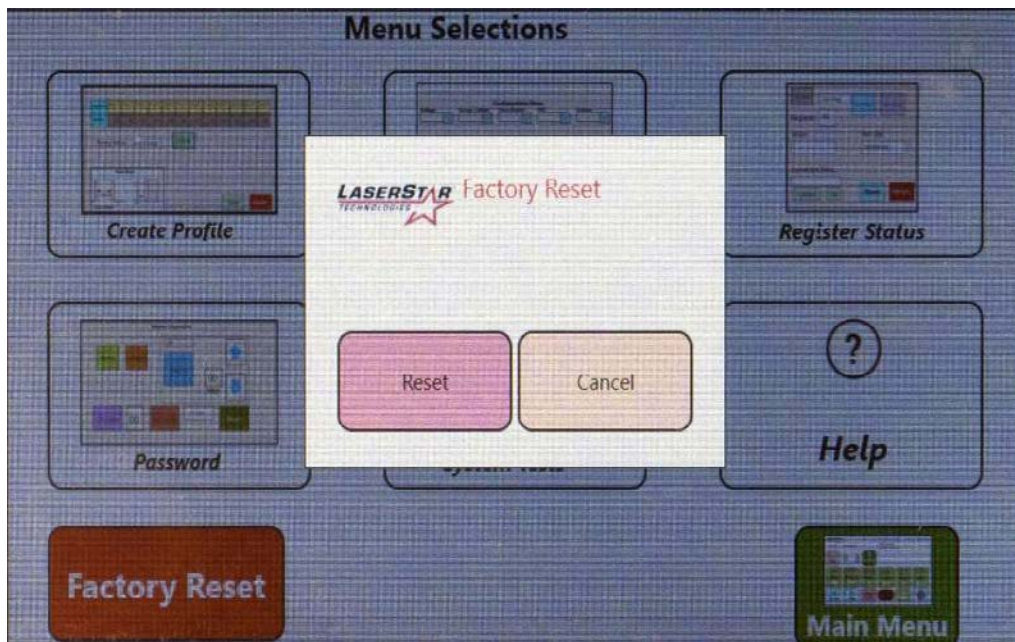


**Figure 36**  
(Video Support Topic  
[Press Play])



**Figure 37**  
(Video Support Topic  
[Fullscreen])

## Messaging & Touchscreen Display Operation (continued)



**Figure 38**  
(Factory Reset [Call  
for Assistance])

## Joystick Operation



The operating parameters can be adjusted using the joystick, which is located inside the welding work chamber. For details, reference the section on Internal Control Elements.

### Storing Operating Parameters

The device's controller has stored memory locations with sets of pre-defined or pre-programmed operating parameters — each optimized for a specific application or material. Selecting from these pre-defined parameter settings allows the operator to utilize the same tried-and-tested operating data that was used previously to yield good results. **(Note: For additional details on pulse shape, be sure to reference the Appendix, as well as the section on Pulse Performance Technology.)**

In order to more readily identify the various memory locations, they can be assigned a unique name. Memory locations may already have default designations, but these can be changed, as needed.

#### A stored set of parameters consists of the following:

(Note: The definitions for these parameter recipes are located in the section entitled **Operation > Setting Operating Parameters.**)

(Note: With some applications, adjustments to voltage are intended to compensate for flashlamp decay; this way the joule output is the same for the selected screen voltage. However, there are instances when the operator will need to maintain the same screen value for volts (while the actual voltage is the screen value  $\pm$  the offset value). For details, reference **Operation > Setting Operating Parameters.**)

- Pulse Width (PW [ms])
- Burst Mode
- Hertz (single pulse [0 Hz]; multi-pulse [ $\geq 1$  Hz])
- Focus Setting (Dia [mm])
- Pulse Shape (see section on Pulse Performance Profile [P<sup>3</sup>] Technology)

**(Note: The beam expander offset allows the user to maintain the same screen value for the focus setting (Dia [mm]), despite that the beam diameter is actually the screen value  $\pm$  the offset value.)**

**Storing Operating Parameters Continued on Next Page**

## Storing Operating Parameters (continued)

### **Important Advisory:**

- Restoring factory defaults for the memory will erase modifications that were saved or altered by the user.  
**(Note: The operator should keep a back-up copy of all stored operating parameters.)**

You can use the joystick to program the parameters for the memory or you can use the touchscreen display. The **Save button** on the touchscreen allows the operator to save a program into a memory location.

Operator Action	System Response
<b>See methods below for details on storing parameters.</b>	
Press the <b>Change</b> button; type in the name of the new recipe setting.  Next, press <b>OK</b> . Then, <b>Save</b> .	The <b>alphanumeric keypad</b> will appear.  Two (2) options will appear on the screen — <b>Save</b> and <b>Cancel</b> .  The recipe name will be saved in the next available memory cell slot and will be assigned a recipe number.
Select the parameters you wish to save.	Using the joystick control or touchscreen display, adjust the parameters to the desired settings.
> Press <b>Save</b> .	The values for <b>pulse shape</b> are stored with the welding parameters; these settings are viewable on the touchscreen display (main menu).

**(Note: On the touchscreen display, when storing parameters with text, use the [ABC] or alternatively, switch to [123] on the alphanumeric keypad.)**

## Recalling Stored Recipes

The joystick or touchscreen display can be used to recall operating parameters (recipes) that have been previously stored into a specific memory location (see the section entitled “**Storing Operating Parameters**” on **pages 95 – 96**).

Operator Action	System Response
<p><b>There are three methods for setting a recipe; see below for details.</b></p>	
<p>Select the memory location to be used by pressing the <b>Change button</b> (upper-left corner of the touchscreen display).</p> <p>Next, use the <b>up</b> and <b>down arrows</b> to adjust the recipe location number.</p> <p>Press the <b>Set Recipe button</b> to display and review the values for the parameter settings on the display.</p> <p>When the recipe is set, the values will be green.</p>	<p>The selected recipe location’s welding parameters will be visible while the memory location number is changed.</p>
<p>Press the recipe cell number.</p> <p>Press the <b>number box</b>; enter the number for the desired recipe.</p> <p>Next, press <b>OK</b>. Then, <b>Done</b>.</p> <p>Next, press <b>Set Recipe</b>.</p>	<p>The <b>Done button</b> will appear.</p> <p>The <b>alphanumeric keypad</b> will appear (<b>Figure 7</b>).</p> <p>All parameter settings will now turn green, indicating that the recipe has been set.</p>
<p>The joystick can be used to select a memory location. Using the joystick, navigate <b>right</b> to highlight the <b>up</b> and <b>down arrows</b>.</p> <p>Next, use the joystick to move <b>up</b> or <b>down</b> to select the desired recipe.</p> <p>Now, move the joystick <b>right</b> to highlight the <b>Set Recipe button</b>. Then, move <b>up</b> to set the recipe.</p>	<p>The <b>arrows</b> will highlight.</p> <p>The <b>Set Recipe button</b> will highlight.</p>



**If there are no parameter values stored in the selected memory location number, the set values will remain unchanged. If the capacitor bank voltage is reduced as a result of the values selected, it is automatically reduced to the new value by pulse discharge.**

## Welding (touchscreen display and joystick)

Operator Action	System Response
Place the workpiece inside the welding work chamber.	
Set or adjust the weld parameters (recipe), optimizing for the selected material.  <b>(Note: Use the joystick control or alternatively, the touchscreen display.)</b>	The <b>Done button</b> will appear.  The <b>alphanumeric keypad</b> will appear ( <b>Figure 7</b> )  The parameter settings will turn green; this indicates that the recipe has been set.
Insert both hands through the hand openings and into the welding work chamber.  With the joystick, navigate <b>right</b> or <b>left</b> until the <b>Safety Shutter button</b> is highlighted.  Next, use the joystick to move <b>up</b> or <b>down</b> ; this will <b>open</b> or <b>close</b> the <b>Safety Shutter</b> .	The <b>arrows</b> will highlight.  The <b>Set Recipe button</b> will highlight.
Depress the <b>foot pedal switch</b> ; fire the laser.	A laser pulse is released.



**While the foot pedal is engaged, you should never place your hands or other body parts directly inside or beneath the path of the laser's cross-hair; when a laser pulse is released (and with skin contact), there's potential risk for serious injury, including severe burns.**

The dimmer control (located inside the welding work chamber) can be used to adjust the brightness level inside the work chamber and better illuminate a workpiece or part. Check the brightness using the stereo microscope; appropriate brightness is dependent on the material and properties of the workpiece.

**(Note: If the reference value for the voltage has been reduced, for safety reasons, the safety shutter will remain closed.)**

When welding (and while using inert gas), keep in mind that the outlet is located at the end of the gas tubing and should be positioned near the laser's focal point. For most applications, adequate positioning is at the edge of the visual field (above the focal plane) for the stereo microscope.

## Optimizing Welding Results

With welding applications — in order to optimize results, workpieces must always be properly positioned within the focusing area of the laser beam; this is a determining factor that affects weld quality and the final outcome.

Operator Action	System Response
<b>Proper positioning for workpieces — both horizontal and vertical, is important.</b>	
Look through the <b>stereo microscope</b> and join the workpieces together — adjust the workpieces, as needed.	The cross-hair indicates the exact position of the laser's pulse spot.
When the welding point appears sharply in focus (and within the cross-hair), partially press down the <b>foot pedal switch</b> .	The inert gas supply will be enabled.
Depress the <b>foot pedal switch</b> down fully.	the view shutter will activate automatically for a short duration; this occurs with each laser pulse.
To release consecutive laser pulses (with single-pulse mode), the <b>foot pedal switch</b> must be partially released, then fully (and repeatedly) depressed down. With continuous-pulse mode, laser pulses are fired consecutively (for as long as the <b>foot pedal switch</b> remains fully depressed).	A laser pulse is released; this can be single or consecutive, depending on the operator's chosen action.
When you have finished welding, be sure to place all workpieces down inside the work chamber to cool.	



**In some instances, and with specific materials, establishing suitable parameters (voltage, pulse length, pulse frequency, beam diameter, and pulse shape), and additionally, the flow rate for the argon (inert) gas will need to be determined based on a period of trial and error. In many cases, the quality of a weld point can also be vastly improved when the laser pulses are fired consecutively, and within a short span of time.**

Following adjustments to the voltage value, a pause in activity may occur; this happens while the device is charging or discharging energy. During this recovery period, the buttons on the display will switch to grey. The timing for recovery can range between 0.1 and eight (8) seconds, depending on the values that have been set for the voltage and laser pulse length. When the new settings are finalized, the set recipe settings will return to green.

## Setting Operating Parameters

The view shutter is controlled electronically. A laser pulse will only be released if the view shutter is operating properly. Additionally, there is an optical filter in the viewing optic that blocks UV and laser light.

## Resetting Pulse Count

For information on resetting the pulse count, be sure to reference **Operating Parameters > Messaging & Touchscreen Display Operation**.

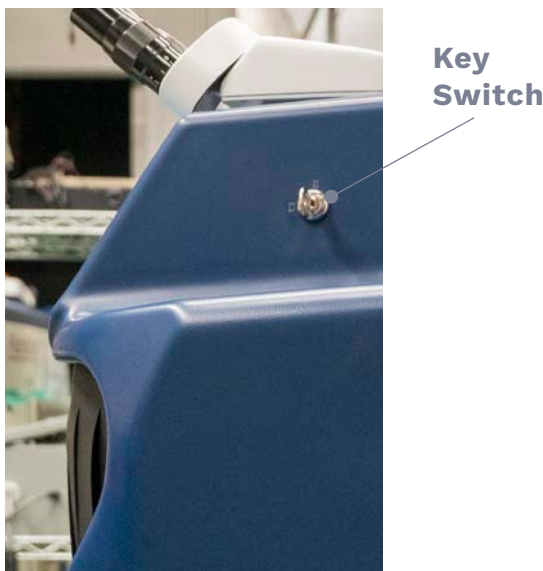
## Text Input Mode

For information on using text entry mode, be sure to reference **Operating Parameters > Messaging & Touchscreen Display Operation**.

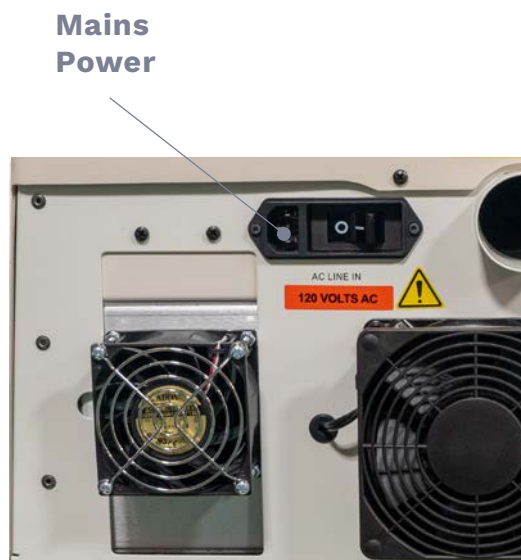
## Switching “Off”

1. **The control system must be the first to shut down, using the on-screen “Shut Down” icon. Wait for the screen to go black before continuing.**
2. Turn the **key switch** to the “0” position.
3. Turn the **mains power switch (rear of machine)** to position “0”.
4. Close and turn “off” the inert gas valves (gas cylinder valve).

Remove the key from the **key switch** and be sure to store it securely; it should only be accessible to authorized personnel.



**Figure 39a**  
(Switching “OFF” - Front-right of system)



**Figure 39b**  
(Switching “OFF” - rear of system)

## Status Monitoring and Indicators

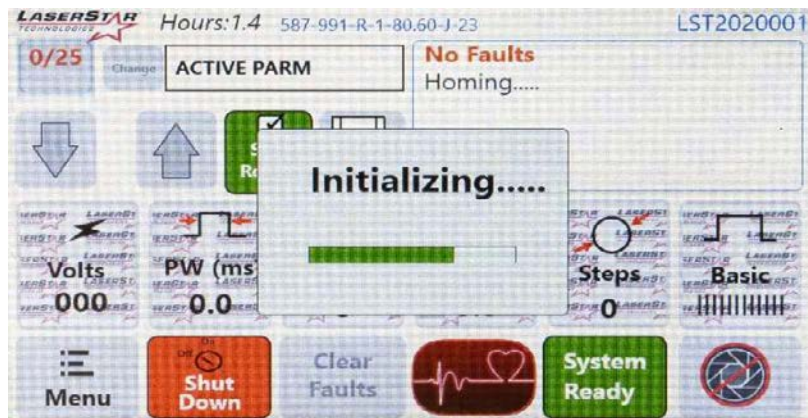
During the self-test diagnostics, which begin immediately after the device has been switched “on,” the LaserStar Technologies Corporation® logo is displayed, followed by the start of the software initialization. **(figures 40 & 41)** During operation, the current status of the laser is indicated by the beating heart on the touchscreen display. If the heart icon is broken, the system is not ready to weld. **(figure 43)**

**The micro-controller monitors the conditions for pulse release on the basis of the following criteria:**

- If the safety shutter is open, a laser pulse can only be released via the pedal switch.
- In case the safety shutter is closed, the operator cannot release a laser pulse / lamp flash. (This is to avoid unplanned laser pulse release.)
- In principle, the remote interlock prevents a laser pulse release.
- A Remote Interlock failure shuts off the flashlamp power supply.



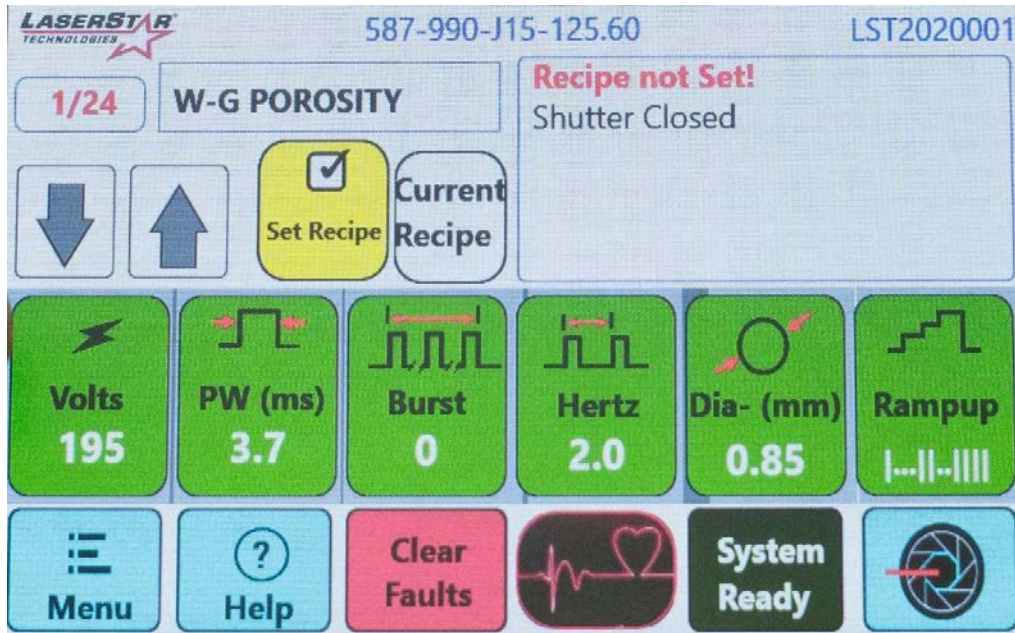
**Figure 40**  
(Self-Test Screen)



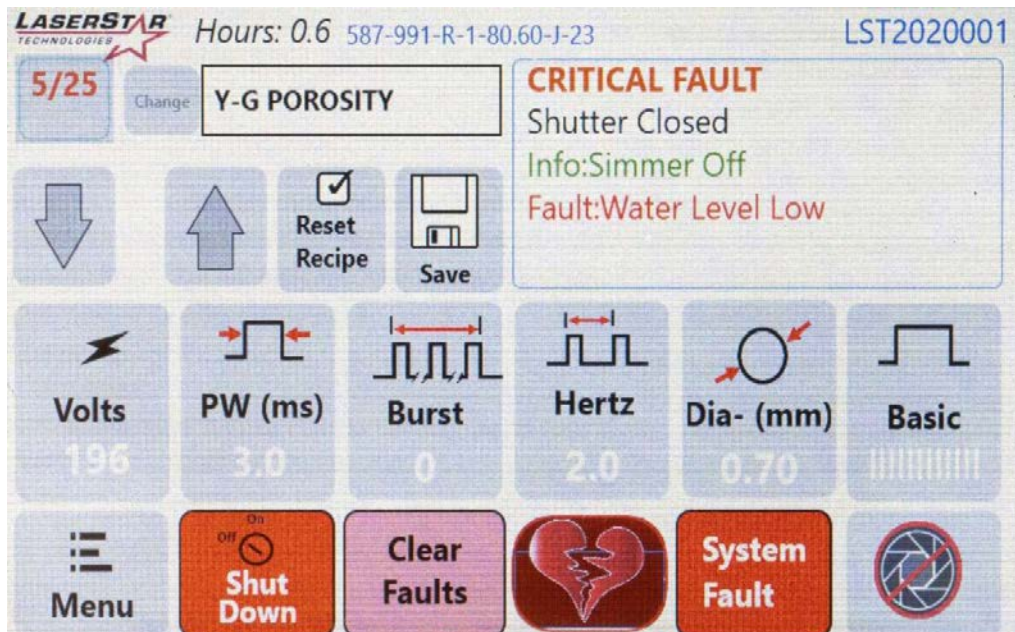
**Figure 41**  
(Initializing)

**Status Monitoring and Indicators Continued on Next Page**

## Status Monitoring and Indicators (continued)



**Figure 42**  
(Beating Heart Status)



**Figure 43**  
(Broken Heart Status)

**(Note: The entire screen will be gray and the laser will not fire until the Critical Fault has been cleared.)**

## Floor Stand Operation

This system has an optional adjustable Floor Stand. It comes with a pendant that will raise and lower the stand to the desired height. If the adjustable floor stand is ordered with the system, it will already be attached to the stand on arrival. Refer to the respective laser's Setup Guide if the laser needs to be installed or uninstalled from the floor stand.



**Figure 44a-b**  
(Floor Stand  
Power Plugs)



**Figure 44c**  
(Floor Stand  
pendant)

<b>Adjustable Floor Stand Technical Specifications</b>	
Bottom Plate Dimensions	L30xW24
Top Plate Dimensions	L22xW21.5
Lowest Position	22 in. from floor
Highest Position	33.5 in. from floor

## **Passwords & Restricted Access** **(model & option dependent; factory installed —** **Reference Appendix, Section B)**

### **Important Advisory:**

The restricted access feature is intended to prevent unauthorized changes to the device's welding parameters; this feature is installed prior to shipping from LaserStar Technologies Corporation®. The operator can choose to enable or disable restricted access and password protection whenever they choose.

<b>LaserStar Technologies: Important Contacts</b>		
<b>Sales &amp; Training</b>	<b>Service &amp; Support</b>	<b>Corporate Office</b>
(407) 248-1142 <a href="mailto:sales@laserstar.net">sales@laserstar.net</a>	1-888-578-7782 <a href="mailto:service@laserstar.net">service@laserstar.net</a>	2461 Orlando Central Pkwy. Orlando, Florida 32809, USA

## V. Maintenance

### Overview and Requirements

Routine maintenance is a requirement for ensuring the safe and optimal operation of the welder. Regular maintenance intervals must be scheduled in accordance with the manufacturer's recommendations and requirements.

#### Before maintenance can be carried out, the following safety measures must be observed and followed:

- Disable systems, subsystems, and auxiliary equipment by turning "OFF" and disconnecting from power sources or live components.
- Ensure that all the disconnected equipment has been secured against being switched "ON" again, whether automatically (e.g. vibration) or inadvertently (e.g. operator error). Secure the **Mains Power Switch** with a padlock (the mechanical locking device provided may be) used or alternatively, remove the fuses. Verify that all warning indicators are properly functioning and remain alert while maintenance is being carried out.
- Using a voltage meter or voltage tester, check whether the equipment is "live." Measure the conductors against one another and also against the protective ground conductor.
- When reconnecting the equipment, **remember, the equipment should always be grounded first.** With low-voltage devices, short-circuit the capacitors, and for high-voltage devices, short circuit both the capacitors and high-voltage lines. When service has been concluded, be sure to remove the grounding and shorting jumpers.



Warning!

**While working with an open device, OSHA regulations must be followed for accident prevention with regard to laser radiation or equivalent national or international regulations (e.g. EC Directive 608 or IEC Publication 825). Remember also to wear the appropriate laser protective eyewear.**

- If there is a risk of touching "live" components while at the worksite, and it is not possible to disconnect these components from their voltage source, they must be covered with a reliable and sufficiently strong insulating material. If the components cannot be covered, another method must be used to prevent direct contact. Once precautions are in place, be sure also to cover the workspace with plastic sheeting, paneling, or a rubber mat.
- After maintenance is concluded, the service personnel must verify that the equipment is safe to operate.
- When replacing components, use only Laser Star Technologies Corporation® approved parts and accessories.



Caution!

**When carrying out service or maintenance tasks, never work alone. A second person who is familiar with the risks posed by high-voltage electricity and laser radiation should always be present for these activities. This person will also provide support in the event of an emergency, turning off the equipment and administering first aid, if necessary.**



Warning!

**This device complies with all generally recognized technical standards and regulations, including those set forth by OSHA, EC, EN, DIN, and VDE. The laser is ignited and operated using dangerous high voltage (>1kV) and special care must be taken when working on the flash-lamp power supply. If the electrical or electronic components are being measures while the machine is "ON" it is critical to maintain required clearances (for details, refer to Installation, Section III. When working with electrical equipment of this kind, relevant safety regulations must be followed (OSHA, or the equivalent national or international standards).**

## Maintenance Intervals



To optimize performance and minimize premature machine failure, maintenance routines should be carried out at the recommended intervals.

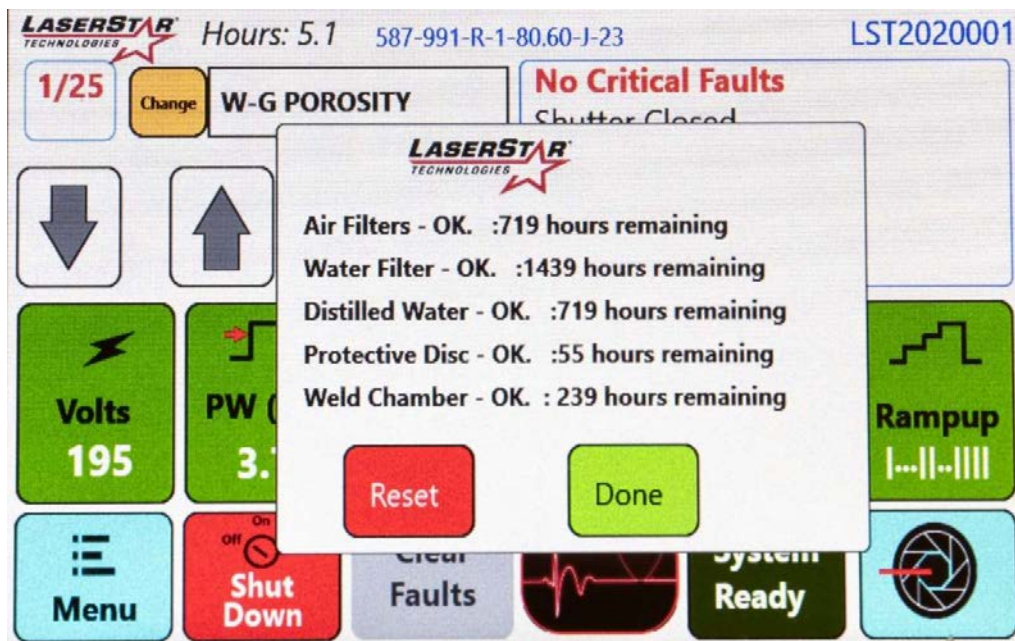
The welding workstation is programmed to alert the operator about upcoming or anticipated maintenance requirements. Maintenance reminders will appear on the touchscreen display, as indicated in the table below, which lists these tasks and their anticipated intervals.

<b>Maintenance Intervals: Alert Reminders</b>			
<b>Use <u>only</u> LaserStar Technologies Corporation® approved parts and accessories.</b>			
<b>Alert Notification</b>	<b>Interval</b>	<b>Hours (based on general usage within an 8-hour work day)</b>	<b>Reset Method</b>
Protective Disk (cleaning)	7 days	56 hours	Press the <b>Reset button</b> to reset
Welding Chamber (cleaning)	30 days	240 hours	Press the <b>Reset button</b> to reset
Air Filter(s) (change)	90 days	720 hours	Press the <b>Reset button</b> to reset
Distilled or Deionized Water (change)	90 days	720 hours	Press the <b>Reset button</b> to reset
Distilled or Deionized Water Filter (change)	180 days	1440 hours	Press the <b>Reset button</b> to reset

## Maintenance Alerts (continued)



The laser will indicate with a beep when maintenance is due. Alerts appear on the touchscreen in red; pressing the Reset button will clear the alert (Figure 44 below). The Beating Heart button allows the user to view the hours remaining before maintenance is due for a specific component.



**Figure 44**  
(Maintenance Alerts)

## Maintenance Intervals (continued)



**The maintenance schedule is dependent on both the environment and general usage. The operator should determine the appropriate maintenance intervals.**

### Daily: (a)

1. The outside surface of the welder's body enclosure, the work chamber, and safety material (surrounds the outside of the splash-protective observation window) should be cleaned using a cloth that's been dampened with water or other non-abrasive cleaner. **If you choose to use 70% isopropyl alcohol, a flammable liquid, be sure there's no contact with the device's touch screen display; this will damage the display. Additionally, you should never use strong cleaning agents, such as powders or solvents to clean the equipment.**
2. The splash-protective observation window should be visually checked for cracks, voids or other damage. **If you discover damage, be sure to replace the splash-protective observation window before using the device.** (For additional details on this process, be sure to refer to the section entitled “**Replacing the Splash-Protective Observation Window and Laser Protective Window**” later in this chapter.)
3. The protective disk, which is located inside the work chamber, should be unscrewed from the focus lens and cleaned with a lens cleaning solution. We recommend LaserStar Technologies Corporation® Cleaning Solution (part number: 810-2353), which can be conveniently purchased from our [e-store](#). If you prefer to use cleaning wipes (part number: 810-2356 [quantity: 1] or 810-2354 [quantity:90]), these are also available to purchase from our [e-store](#). **(Note: If opting for 70% isopropyl alcohol, be sure to use with a lint-free cleaning cloth. After cleaning, polish with a clean, lint-free wipe to remove any hazy residue.)**

Over time, and with continued use, you will notice metal splashes adhering to the surface of the protective disk; there is a danger of local heating at these splash points that can result in cracking or possible destruction of the focus lens. Eventually, the protective disk will need to be replaced. **Caution: When replacing the protective disk, always replace with a new component; never reinstall the protective disk with the side that has metal splashes facing upward.**

### Weekly: (b)

1. Check the alignment of the cross-hair with the device's pulse spot. (for additional details and step-by-step instructions on this process, see **Operation > Optical Alignment**.)
2. The splash-protective observation window (located behind the laser protective window) should be cleaned and checked for scratches, cracks, and holes.

**Maintenance Intervals Continued on Next Page**

## Maintenance Intervals (continued)

### Monthly: (c)

1. Inspect the welding chamber protective housing (i.e. arm cuffs and chamber door) for damage. **This device must not be used if any of the protective housing components are damaged.** If you discover damage, be sure to contact LaserStar Technologies Corporation® Service Department for support, by calling 1-888-578-7782.



Warning!

**Disconnect the AC Mains plug and wait five (5) minutes for the flashlamp power supply to discharge.**

2. Use a vacuum with an extension attachment to clean the heat exchanger fins. **Caution: The heat exchanger fins are both extremely sharp and delicate; when removing dust or debris from the fins, be careful not to cut yourself or damage this component.**
3. Check the water level inside the distilled or deionized water reservoir (for additional details, be sure to reference **Service > Section B: Refilling or Topping Off the Distilled or Deionized Water Reservoir**).
4. Check the exhaust system filter (located inside the welding chamber); if dirty, be sure to replace. (refer to **Service > Section B: Welding Chamber Exhaust Filter Replacement** within this manual)
5. Check all air filters inside the cabinet enclosure; if dirty, be sure to replace.
6. Adjust the device's power settings as follows: 250V, 1 ms, 0.0Hz, 0.20mm (beam diameter)
  - Position the supplied flash paper at the bottom of the welding chamber; fire a single laser pulse.
  - Compare the pulse spot with the samples that were shipped and included with purchase. If you notice differences in quality, be sure to contact LaserStar Technologies Corporation® Service Department for support.

### Quarterly: (d)

1. Change the distilled or deionized water every three (3) months.
2. Change the distilled or deionized water filter every six (6) months, depending on usage. **(Note: Reference Service > Changing the Distilled or Deionized Water & Replacing the Distilled or Deionized Water Filter.)**

### Annually: (d)

Perform routine maintenance at the scheduled intervals outlined above (or as needed, in accordance with individual usage).

## Protective Disk Replacement

The protective disk, which is constructed from glass, prevents the lens from being damaged by mechanical influences (i.e. metal splashes or dust). An anti-reflective coating is present on both sides of the disk and helps to minimize the chance of loss as a result of absorption.

1. Turn the **mains power switch** “OFF” or “O.” Wait five (5) minutes for the lights to cool.
2. Insert both hands into the hand opening.
3. Remove the fixed gas nozzle by pressing the button (located on the left-hand side of the nozzle).
4. Remove the ring lamp by unscrewing the two (2) black thumb screws. The lamp will be plugged into the top of the welding work chamber.
5. Unscrew the knurled ring from the underside of the lens, turning counter-clockwise; remove the component from the welding chamber — ensuring that it remains horizontal, if possible.
6. Replace the previous protective disk with the new one.
7. Turning clockwise, secure the knurled ring together with the new protective disk, re-affixing to the underside of the lens.
8. Replace the ring lamp, setting in place around the focus lens. With the ring lamp in place, tighten the two (2) black thumb screws.
9. Replace the fixed gas nozzle by pushing the component into the receptacle; you will hear the nozzle snap into place.

## Refilling the Distilled or Deionized Cooling Water, Bleeding the Pump, etc. (reference Service)

## Splash-protective Observation Window and Laser Protective Window Replacement

**The splash-protective observation window is a combination of two (2) pieces:**

- The splash-protective window (inside) protects the laser protective window from soiling and damage.
  - The protective window (outside) prevents the emission of radiation from laser light.
1. Remove 6 cross heads screws holding the rear cover in place and remove the rear cover (#2 Phillips drive needed).
  2. Remove 6 cross head screws holding the blue front cover in place
  3. Pull front cover forward and identify/cut cable ties (as needed) holding wires coming from front cover screen. These cables will be on the left side of the system relative to the operator position. (cable tie cutter needed if cutting is required)
  4. Rotate front cover from left to right relative to operator position until laser protective window mount is accessible



Caution!

**Use care when handling and replacing the splash-protective observation window. Be careful not to scratch the window's surface. With rough handling, there is potential to damage the component.**

5. Loosen two m3 hex nuts (5.5mm nut driver or wrench required)
6. Remove old laser protective window and replace
7. Tighten two m3 hex nuts (5.5mm nut driver or wrench required)
8. Place blue front cover back into position, replace any cable ties that were cut
9. Reinstall all 6 cross head screws and tighten
10. Reinstall rear cover and all 6 of its cross head screws

**(Note: If you hear clattering after installation is complete, the component has not been properly installed; be sure to reinstall the window if this is the case.)**

**Splash-protective Observation Window and Laser Protective Window Replacement Continued on Next Page**

## Filter Replacement and Chamber Exhaust

1. Fully power down the system and disconnect its AC supply.
2. Wait five (5) minutes.
3. Remove the chamber exhaust filter cover on the rear of welding work chamber.
4. Remove the filter and replace.
5. Reinstall the filter cover.
6. Reconnect the main AC power source.
7. Check for the fan turning on and air being exhausted from the rear of the enclosure.



Warning!

**You should never attempt to clean the machine's air filter; this component is intended for single-use and must be replaced periodically, as outlined in the section on maintenance. Never beat or blowout the filter with compressed air; this will compromise the integrity of the component and destroy the filter medium. In addition, risks are presented when pollutants that have adhered to the filter are cycled back into the air in the workspace.**

### Notes

---

---

---

---

---

---

---

## Touchscreen Display

It's important to know, the touchscreen display is sensitive to chemicals, much as is a pair of glasses with plastic lenses (usually polycarbonate with a glare reduction coating). In fact, the cleaning kit often supplied with a pair of glasses is a great option for safely and effectively cleaning the touchscreen display; it typically includes a microfiber cloth and a gentle cleaning solution.

### **When attempting to clean your machine's touchscreen display, be sure to keep the following guidelines in mind:**

- Use a soft lint-free cloth. The 3M Microfiber Lens Cleaning Cloth is especially recommended for cleaning touchscreen displays without requiring liquid cleaner.
- The cloth may be used dry, or lightly dampened with a mild cleaner or Ethanol.
- Be sure the cloth is only lightly dampened, not wet. Never apply cleaner directly to touchscreen surface; if cleaner is spilled onto the display surface, soak it up immediately with an absorbent cloth.
- Cleaner must be neither acid nor alkali (neutral pH).
- When using cleaner, avoid contact with the edges of the film or glass.
- Wipe the surface gently; if there is a directional surface texture, wipe in the same direction as the texture.
- Never use acidic or alkaline cleaners, or organic chemicals such as: paint thinner, acetone, toluene, xylene, propyl or isopropyl alcohol, or kerosene.
- Suitable cleaning products are commercially available pre-packaged for use; one example of such a product is Klear Screen™ <<https://www.nushield.com/klear-screen-wiping-pads>> or commercially available off-the-shelf retail brands such as Glass Plus® Glass and Surface Cleaner made by Reckitt-Benckiser <<http://www.glassplus.com/>>.
- Use of incorrect cleaners can result in optical impairment of touchscreen and/or damage to functionality.

**(Note: Most cleaning products contain between 1-3% isopropyl alcohol by volume, which is within acceptable limits for cleaning resistive touchscreen displays. Some products, however, contain ingredients like ammonia, phosphates or ethylene glycol, which are not acceptable. When making a decision to purchase products to clean the touchscreen display for your device, be sure to carefully review the list of ingredients on the label.)**

## VI. Troubleshooting

(Note: Before troubleshooting is carried out on the machine, be sure to reference important safety protocols outlined in **Maintenance; section V** within this manual.)

### General Information

All messages, alerts, and system faults are displayed in the upper right-hand corner of the touch-screen display. System faults are categorized with the following criteria: **critical**, **non-critical**, and **non-faults**. If there is a fault, it must be eliminated to resume working. Once all faults have been eliminated, press the **Clear Faults** button in the alarm box for the system to reset the faults.



**While carrying out service-related activities with an open device, you must comply with regulations set forth by OSHA for accident prevention with regard to laser radiation or the equivalent national or international regulations (e.g. EC Directive 608 or IEC Publication 825). Be sure also to safeguard your eyes and wear appropriate laser protective eyewear.**

### Equipment Malfunction

If you experience a malfunction with your machine that cannot be eliminated through one of the actions outlined in the previous sections for Maintenance or Troubleshooting, be sure to document your results and immediately contact LaserStar Technologies Corporation® Service Department for support, by calling [1-888-578-7782](tel:1-888-578-7782).



**Service and maintenance tasks should only be performed by technicians who are affiliated with LaserStar Technologies Corporation® and who are appropriately trained; other properly trained personnel; personnel who are supervised by trained personnel (in-person or by phone); or by those who have read and understand the service-related protocols within the sections for Operation, Section IV and Maintenance, Section V within this manual.**

<b>LaserStar Technologies: Important Contacts</b>		
<b>Sales &amp; Training</b>	<b>Service &amp; Support</b>	<b>Corporate Office</b>
(407) 248-1142 <a href="mailto:sales@laserstar.net">sales@laserstar.net</a>	1-888-578-7782 <a href="mailto:service@laserstar.net">service@laserstar.net</a>	2461 Orlando Central Pkwy. Orlando, Florida 32809, USA

## Diagnosing & Troubleshooting Basics

System Messages	Possible Cause
Right Hand Sense*      HNDS	The right hand proximity sensor is not seeing operator's hand in machine.
Left Hand Sense*      HNDS	The left hand proximity sensor is not seeing operator's hand in machine.
Left Door Sensor*      DR INT	Left chamber door is open (Reference Service Section "E")
Front Door Sensor*      DR INT	Front chamber door is open (Reference Service Section "E")
Right Door Sensor*      DR INT	Right chamber door is open (Reference Service Section "E")
Single Pulse Mode	Hertz (0.0) Depressing the foot pedal will only produce one laser pulse.
Multi Pulse Mode	Hertz activated. Depressing the foot pedal will produce multiple laser pulses.
Burst Pulse Mode	Burst activated. Depressing the foot pedal will produce the number of laser pulses that the operator has selected.
Storing Into Memory	Save key depressed. Parameters are being stored into a memory location.
Set Recipe	Set Recipe key depressed. A saved memory location is being activated.
Safety Shutter Closed	The Open Shutter (O) button has not been pressed to allow the safety shutter to open.

**Diagnosing & Troubleshooting Basics  
Continued on Next Page**

## Diagnosing & Troubleshooting Basics (continued)

System Messages	Possible Cause
Safety Shutter Open	The Open Shutter (O) button has been pressed and the safety shutter is open.
Cap Supply Not RDY	Displayed continually (third row on the touchscreen display. Intermittent: Power supply is not recharged to the specified voltage
Simmer Supply Off      Smr Off	Check and (or) change Flashlamp. (Reference Service Section / Simmer for details on lamp status)
Beam Expander Low Fault	Beam Expander “zero” signal not detected. Operation can continue, however, beam diameter is not changing.
Beam Expander Hi Fault	Beam Expander “Full Limit” signal not detected. Operation can continue, however, beam diameter is not changing.
<b>Error Reported (critical)</b>	
Water Flow Low      Flw Lw	Prime the water pump by opening the petcock or equivalent located near the water bottle. Are the inlet and outlet lines connected to the tank? Is the petcock closed after priming (model dependent)?
Water Level Low      Wtr Lw	Check and fill the distilled or deionized water inside the water reservoir.

**Diagnosing & Troubleshooting Basics  
Continued on Next Page**

## Diagnosing & Troubleshooting Basics (continued)

System Messages	Possible Cause
Water Temp High      Tmp Hi	The cooling water has exceeded its normal operating temperature; leave machine idle and leave “on” to cool.
CHG Supply Over Temp      Chg Tm	The cap-charging supply has exceeded its normal operating temperature; leave machine idle and leave “on” to cool.
CHG Supply Over Volt      Ovr V	The calibration for the charging supply and cap supply is “off”.
Cap Discharge Fault      Cap D	The power supply is not discharging.
IGBT Fault      IGBT F	Reset the fault and/or turn the key switch “off” and back “on”.
Safety Shutter Fault      Shtr Iv	A safety shutter error has been detected.
View Shutter Fault      Vs TmO	The view shutter is not tripping one (or both) of the “open” and “close” sensors.
External Interlock      R Int 1	Make sure remote interlock on door, etc. is okay. (Note: Or remote interlock shorting connector is fully installed.)
Release Foot Switch	The foot pedal is currently depressed or there’s a short in the foot pedal switch.
Joystick Stuck	Check to make sure the joystick is in the central position. Push the joystick and let it return to the central position to see whether the error message is cleared.

## VII. Parts & Accessories

<b>LaserStar Technologies Corporation® Approved Components</b>	
<b>Description</b>	<b>Catalog Number</b>
Operation and Maintenance Manual (hardcopy)	90-99990-993
Operation and Maintenance Manual (digital; USB flash drive)	90-99991-993
Pump Chamber Repair Instructions (hardcopy)	87-99990-187
Pump Chamber Repair Instructions (digital; USB flash drive)	87-99991-187
AC Simmer Supply	405-4086-01
Air Filter Kit (2 side, 1 rear exhaust, 1 chamber fan)	675-101
Alignment Paper	00-10020
Assembly Control Board	187-30-4017
Cap Charging Supply (120 Volt / 60W)	405-4057-116
Cap Charging Supply (230 Volt / 60W)	405-4057-157
Ceramic Reflector	31-10045-2
Distilled or Deionized Water Filter	687-0990
Dual LED Chamber Light Assembly	183-30-0651
Fan Filter: Work Chamber (Pkg. 5)	405-2601-081
Fiber Wipe (Quantity-1)	810-2356
Fiber Wipes (Quantity-90)	810-2354

**Parts & Accessories Continued on Next Page**

## VII. Parts & Accessories (continued)

<b>LaserStar Technologies Corporation® Approved Components</b>	
<b>Description</b>	<b>Catalog Number</b>
Flashlamp Supply (60W/120 VAC)	193-30-1204
Flashlamp Supply (60W/220 VAC)	193-30-2204
Flexible Gas Nozzle Assembly	183-00-0006
Focus Lens Protective Disk	01-10112
Laser Rod Replacement Kit (includes o-ring kit)	187-00-2015
LED Drive Board	193-30-1000
O-ring Flashlamp (x2 required)	466-011
O-ring Replacement Kit (includes o-rings for pump chamber)	187-00-025
O-ring: YAG Rod (x2 required)	466-0915
Pi Control Board	405-2025-203
Power Cord (120VAC Model) SJT 3×14 AWG 60° 300V	405-6199-314
Power Cord (208-240VAC Model) -SVT 3X18AWG 60°C 300V	405-6199-255
Power Cord (208-240 VAC) UK 18 AWG 250V	405-6199-256
Power Supply, 24VDC (All models with AC Simmer)	405-4000-2463
Precision Optical Cleaning Liquid	810-2353

**Parts & Accessories Continued on Next Page**

## VII. Parts & Accessories (continued)

<b>LaserStar Technologies Corporation® Approved Components</b>	
<b>Description</b>	<b>Catalog Number</b>
Protective Eyewear (diffused radiation)	444-IR-101-7-60
Protective View Window	83-10015
Dual light part number	183-30-0651
Quad light part number	183-30-0652
Regulator Kit (argon [inert] gas)	631-099
Remote Interlock Shorting Cap	101-36-0036
Rubber Air Nozzle (Dental Only)	431-068
Temperature Switch: 35C	405-5134-035
Temperature Switch: 66C	405-5134-066
Troubleshooting Connector Kit	121-36-0006
Water Pump (120VAC)	193-00-0011
Water Pump (220VAC)	193-00-0022
Welding Chamber Curtain	83-66038
Work Chamber Fan Screen	61-66019
Wrist Pad Assembly	183-00-0034

## VIII. Original Equipment Warranty - Flashlamp Welder Products

LaserStar Technologies Corporation® (“LaserStar”) warrants for a period of one (1) year, or two (2) years (depending on your purchase) from the date of invoice that this equipment will be free from defects in materials and workmanship as determined at the date of shipment. For details on your warranty period, please reference your purchase invoice.

### (a). Limited Warranty:

After reaching out and notifying the LaserStar Technologies Corporation® Service Department about a problem with your laser system, we will, at our option, elect to:

1. Immediately send a replacement part; or
2. Request defective part(s) or alternatively, the entire laser system be returned to LaserStar Technologies Corporation® Service Department for inspection and repair or replacement; or
3. Schedule a service technician to travel to the buyer’s facility to inspect, troubleshoot, repair, or replace defective components.

### (b). Warranty Exclusions:

1. This warranty does not provide coverage or protection against damage, misuse or abuse of the optical components (lenses, mirrors, glass, crystal, etc.) associated with the device;
2. This warranty does not provide coverage or protection against damage, misuse or abuse of the computer hardware;
3. It is required to connect an exhaust device to ensure ablated materials and/or harmful gases are removed from the system which can potentially cause damage to the laser system. Failure to connect an exhaust system can result in voiding the warranty.

4. This warranty does not provide coverage or protection for consumable parts (flashlamp [or flashlamp connectors], flow plate, resonator reflectors, protective disk, air filter, water filter, deionized water, cuffs, fuses, halogen lights, LED lamps, final focus lens, etc.).

This warranty is applicable for all equipment, when operated under normal conditions, and in an industrial environment. Any unauthorized use, misuse, neglect, or modification, including use of accessories that have not been previously approved or authorized by LaserStar Technologies Corporation® will void this warranty. Under no circumstance will LaserStar Technologies Corporation® accept liability for loss of use or for any indirect or consequential damage that is the result of customer negligence.

Satisfaction of this warranty, consistent with other provisions herein, is limited to replacement or repair, modification, at the sole discretion of LaserStar Technologies Corporation® and with LaserStar Technologies Corporation® to determine the availability of service personnel, and any absorption of associated service-related expenses.

**The warranty terms previously outlined are valid and will remain in effect only if and when the following obligations are met:**

- (a). Prompt written notification is provided to LaserStar Technologies Corporation® upon discovery of an alleged defect;
- (b). LaserStar Technologies Corporation® examines the equipment, and to its satisfaction, finds that any defect is not the result of misuse, neglect, improper installation, improper operation or improper maintenance, unauthorized repair, alteration or unusual deterioration or degradation of the equipment or parts thereof, due to the physical environment or an electrical or electromagnetic noise environment.

THIS WARRANTY IS IN LIEU OF ALL OTHER WARRANTIES WHETHER STATUTORY, EXPRESS OR IMPLIED, INCLUDING BUT NOT LIMITED TO IMPLIED WARRANTIES OF MERCHANTABILITY OR FITNESS FOR A PARTICULAR PURPOSE, AND THEREFORE, EXCLUDES CERTIFICATIONS OR THE LIKE FOR EQUIPMENT PERFORMANCE, USE OR DESIGN WITH RESPECT TO ANY STANDARD, REGULATION OR THE LIKE (UNLESS, AND TO THE EXTENT, THIS HAS BEEN APPROVED INDEPENDENTLY, AND IN WRITING BY LASERSTAR TECHNOLOGIES CORPORATION®) AND EXTENDS ONLY TO THE BUYER OR CUSTOMER PURCHASING DIRECTLY FROM LASERSTAR TECHNOLOGIES CORPORATION® OR FROM ANOTHER AUTHORIZED RESELLER.

**Return Authorization:**

Whether your equipment is under warranty and in need of repair or otherwise, you must first contact LaserStar Technologies Corporation® to communicate your issue, schedule service, and obtain prior authorization; such authorization shall be granted for each reasonable request. Unless such authority has been granted, the shipment will be refused. Any and all transportation-related expenses associated with evaluation or repair of your equipment, including any refusal of delivery, are the sole expense of the buyer. When sending equipment to our facility, an RMA or CRA number will be assigned to accompany your laser system; this number should remain clearly marked and visible on the exterior of the shipping container.

**Governing Law:**

The sale and purchase of this equipment, including all terms and conditions thereof, shall be governed in accordance with the Uniform Commercial Code and the **laws of the State of Florida.**

**Limited Liability:**

LASERSTAR TECHNOLOGIES CORPORATION® DOES NOT ASSUME RESPONSIBILITY FOR, NOR WILL IT BE HELD LIABLE FOR (A) FINES OR PENALTIES RELATING TO PENALTY CLAUSES OF ANY VARIETY, OR (B) CERTIFICATIONS NOT OTHERWISE SPECIFICALLY PROVIDED HEREIN, (C) INDEMNIFICATION FROM THE BUYER OR OTHERS (RELATED OR NOT) FOR LIABILITY, CLAIMS, ACTION, DAMAGES, LOSS, FINES, COSTS OR EXPENSES, INCLUDING, WITHOUT LIMITATION, REASONABLE ATTORNEY’S FEES, OF EVERY KIND OR NATURE ASSERTED BY ANY PARTY, AND ARISING DIRECTLY OR INDIRECTLY FROM OR IN CONNECTION WITH EQUIPMENT OR REPAIRS RELATING TO THIS PURCHASE ORDER, OR (D) FOR INDIRECT OR CONSEQUENTIAL DAMAGE UNDER ANY CIRCUMSTANCE.

This warranty does provide coverage or protection against damage or defects resulting from accidents that occur while in transit, unauthorized repairs, alteration, misuse, neglect or failure to follow proper safety and operating instructions, fire, flood, freezing temperatures or acts of God.

<b>Authorized Equipment Repairs</b>		
<b>Corporate Office</b>	<b>Rhode Island Office</b>	<b>California Office</b>
<b>Sales, Training, Repairs &amp; Manufacturing</b>	<b>Sales, Training &amp; Repairs</b>	<b>Sales, Training, Repairs &amp; Manufacturing</b>
2461 Orlando Central Pkwy. Orlando, Florida 32809 (407) 248-1142	100 Jefferson Blvd., Ste. 315 Warwick, Rhode Island 02888 (407) 248-1142	20 East Foothill Blvd. Ste. 128 Arcadia, California 91006 (213) 612-0622

## IX. Service

Before service is carried out on the machine, be sure to reference the important safety protocols outlined in **Maintenance; section V** within this manual. Unplug the equipment or switch “off” the circuit breaker and wait five (5) minutes before servicing.



**Service and maintenance tasks should only be performed by technicians who are affiliated with LaserStar Technologies Corporation® and who are appropriately trained; other properly trained personnel; personnel who are supervised by trained personnel (in-person or by phone); or by those who have read and understand the service-related protocols within the sections for Operation; section IV and Maintenance; section V within this manual.**



**While carrying out service-related activities with an open device, you must comply with regulations set forth by OSHA for accident prevention with regard to laser radiation or the equivalent national or international regulations (e.g. EC Directive 608 or IEC Publication 825). Be sure also to safeguard your eyes and wear appropriate laser protective eyewear.**



**Some service-related tasks and diagnostic procedures (i.e. simmer and flashlamp status, tri-door chamber, distilled or deionized water, etc.) will require the welder to be powered “on” for a part of the process. In these instances, extreme caution must be taken to avoid accidents or serious injury. Use caution when observing internal LED indicators, and when topping off the distilled or deionized water reservoir, or purging air from the cooling system. Never touch the electrical components or wiring when the machine is powered “on.”**

### Equipment Malfunction

If you experience a malfunction with your machine that cannot be eliminated through one of the actions outlined in the previous sections for Maintenance or Troubleshooting, please document your results and immediately contact LaserStar Technologies® Service Department for support; either by calling [1-888-578-7782](tel:1-888-578-7782) or emailing [service@laserstar.net](mailto:service@laserstar.net). When reaching out, be sure to include your machine’s model number and serial number with all correspondence. After emailing, be sure to follow-up with a phone call to our service department; this will ensure that we have received all of the details necessary to assist you.

<b>LaserStar Technologies: Important Contacts</b>		
<b>Sales &amp; Training</b>	<b>Service &amp; Support</b>	<b>Corporate Office</b>
(407) 248-1142 <a href="mailto:sales@laserstar.net">sales@laserstar.net</a>	1-888-578-7782 <a href="mailto:service@laserstar.net">service@laserstar.net</a>	2461 Orlando Central Pkwy. Orlando, Florida 32809, USA

## Service A: Distilled or Deionized Water Cooling System

### Tools (supplied or required):

- #2 Phillips Screwdriver
- 1.5 – 6mm Hex Key Wrench Set (metric)
- Adjustable Wrench (1 1/8" range) or 1" Open-end Wrench
- Siphon Hose, Basting Bulb (with 6" spout; McMaster-Carr-#7656K3) or Water Pump (manual or battery-powered)
- Clean Plastic Bucket or Container (≥6 liters or 1.5 gallons)
- Absorbent Paper Towels or Shop Towels (i.e. Scott Shop Original)
- Disposable Vinyl or PVC Gloves (powder-free and DEHP & DOP-free)
- Small Funnel
- Distilled or Deionized Water
- Clean Room or Workspace

**(Note: Before powering “on” the welding workstation, you must first fill the water reservoir with distilled or deionized water. Use only distilled or deionized water; use of tap water or deionized water in this device will damage the equipment and void the machine’s warranty. Be sure also that you’re purchasing Distilled or Deionized water from a reputable supplier.)**

### Initial Filling with Distilled or Deionized Water

1. Turn the machine “off” by turning the key switch to the “0” or “off” position. Next, turn the **mains power switch** to “0” or “off.”
2. Turn the AC power “off” by unplugging the **mains power** cord or shutting “off” the wall disconnect switch; the device should remain “off” for **at least five (5) minutes** before servicing.

**Initial Filling with Distilled or Deionized  
Water Continued on Next Page**

## Initial Filling with Distilled or Deionized Water (continued)

6. Remove the two (2) screws securing the rear cover, as shown in **figure 1**; slide the cover slowly backward (about 6" or 15cm), as shown in **figure 2**.
7. Disconnect the ground wire and slide the cover off; store the cover nearby. Next, remove the blue filter and set aside.
8. The distilled or deionized water bottle is located in the rear of the welder, as shown in **figure 5**. Loosen the distilled or deionized water bottle twist cap, as shown in **figure 6**.
9. Pull out the distilled or deionized water filter assembly and place in a clean bucket as shown in **figure 7**. (**Attention: Do not touch the filter media with your hands. Use lab quality gloves. Be careful not to get any water on the electronics and wipe any water right away that's been spilled.**)
10. Fill the distilled or deionized water bottle up to the black line (max-filter out), as shown in **figure 8**. (Note: The max (filter out) line is a black line located on the side of the distilled or deionized water reservoir.)
11. Install the distilled or deionized water filter.
12. Install and tighten the water bottle twist cap as shown in Figure 9. (Note: Make sure the twist cap is tightly closed.)
13. Make sure the **mains power switch** and **system key switch** are "off." Next, plug in the AC power cord. (**Attention: Failure to comply with the following instructions could damage the pump and void the devices' warranty.**)
14. Turn "on" the welder's **mains power switch** for only 10 to 20 seconds.
  - a. The water should immediately start to flow in the hoses / tubing.
  - b. The water level in the bottle should have dropped by 1 to 2 inches.
  - c. If the water level in the bottle has not gone down in 10 to 20 seconds, immediately turn "off" the machine; wait for 5 minutes and try again.

**(Note: If you have trouble and need support, be sure to reach out to LaserStar Technologies Corporation® Service Department for assistance.)**

**Initial Filling with Distilled or Deionized  
Water Continued on Next Page**

## Initial Filling with Distilled or Deionized Water (continued)

**Attention:** If the pump is still making strange sounds / squealing after completing step 15, turn OFF / “0” the mains power switch and contact LaserStar Technologies Corporation® Service Department.

15. Fill the distilled or deionized water bottle to the black line (Max-Filter Out) line.
16. Install the twist cap and filter.
17. Run the system for **at least fifteen (15) minutes** and then top off the distilled or deionized water bottle to the black line (Max-Filter Out). (**Attention: Make sure the mains power switch is “off” or “0” when topping off the distilled or deionized water bottle.**)
18. Turn “off” or the **mains power switch** and unplug the AC power cord.
19. Install the air filter. Next, connect the ground wire to the top panel and then install the panel.
20. Install the rear cover and secure with the (2) screws. (Note: Reconnect the ground wire and make sure the wire does not get pinched when sliding the cover into position.)
21. Plug in the AC power cord. Turn ON / “1” the Mains Switch (I) and make sure the distilled or deionized water level is above the “Min (Filter In)” line on the rear of the welder.
22. If okay, the system is ready to weld.

## Refilling or Topping Off the Distilled or Deionized Water Bottle

Reference the steps described in “Initial Filling of the Laser Welding System with Distilled or Deionized Water”.

## Replacing the Distilled or Deionized Water and Changing the Water Reservoir Filter

1. Follow steps A1 to A10

**Replacing the Distilled or Deionized Water and Changing  
the Water Reservoir Filter Continued on Next Page**

## Replacing the Distilled or Deionized Water and Changing the Water Reservoir Filter (continued)

2. Use a clean siphoning device, hand pump or squeeze pump to remove the water from the bottle.
3. Remove the old water filter assembly by removing the hose clamp shown in **figure 7**. (Note: A new hose clamp is supplied with the new filter. Make sure you install the hose clamp as shown in **figure 7**.)
4. Install the new water filter assembly without contacting the filter media with your hands (Note: Wear lab quality gloves.)
5. Follow steps A11 to A23. (Note: Use a new bottle of distilled or deionized water.)

## Removing the Distilled or Deionized Water Bottle from the Machine (storage and transport)

Reference the steps described in “Initial Filling of the Laser Welding System with Distilled or Deionized Water” with the following additional steps.

1. Follow steps A1 to A10
2. Use a clean siphoning device, hand pump or squeeze pump to remove the water from the bottle.
3. Re-install the filter into the water bottle.
4. Make up two air hose assemblies (~2 ft in length) for use with a manual air pump or clean shop air (no water or oil and  $\leq 30$  psi): One air hose assembly with a male garden hose fitting and a second air hose assembly with a female garden hose fitting. Both air hose assemblies will have fittings on the other end compatible with the air supply.
5. Slowly disconnect the front cooling hose female fitting from the “pump chamber male cooling hose fitting as shown in **figure 10**. (Attention: Place a paper towel below fitting before loosening to collect any water.)
6. Install the rear cover and secure with the (2) screws. (Note: Reconnect the ground wire and make sure the wire does not get pinched when sliding the cover into position.)

### Removing the Distilled or Deionized Water Bottle from the Machine Continued on Next Page

# Removing the Distilled or Deionized Water Bottle from the Machine



**Figure 1**  
(Distilled or Deionized Water Level [Rear of Welder])

**“Maintain water level above the ‘Min Fill’ line using distilled or deionized water”**

Note: The max (filter In) line is located on the side of the bottle inside the enclosure.

## Removing the Distilled or Deionized Water Bottle from the Machine Continued on Next Page

## Removing the Distilled or Deionized Water Bottle from the Machine (continued)



Rear Cover  
Screws  
(Same on  
other side)

**Figure 2**  
(Side View of  
Rear Cover)

Carefully slide Rear cover back  
until it can be lifted off.



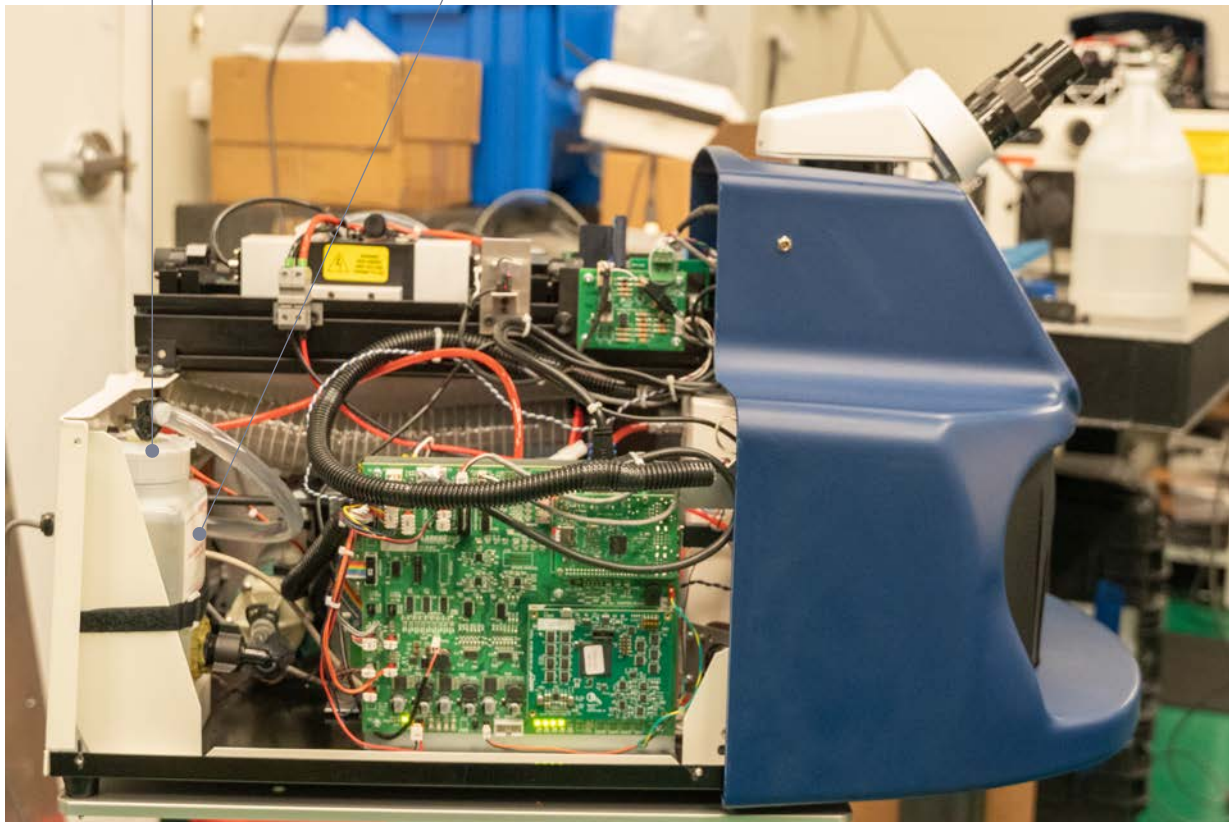
**Figure 3**  
(Welder Rear cover  
Being Removed)

Remove the  
Air filter

## Figures and Parts Labeling (continued)

Distilled or Deionized  
Water Bottle

Max Line  
(Filter Out)



**Figure 4**  
Distilled or Deionized Water  
Bottle [Rear of Enclosure]

### IX. Service, Figures and Parts Labeling Continued on Next Page

## Figures and Parts Labeling (continued)

Hose Clamp  
(463-089)



Remove  
Distilled or  
Deionized  
Water  
Bottle Twist  
Cap

**Figure 5**  
(Remove the Distilled or  
Deionized Water Bottle Cap)

**IX. Service, Figures and Parts  
Labeling Continued on Next Page**

## Figures and Parts Labeling (continued)

Lift the filter assembly out of the bottle and place in clean container (Note: Distilled or Deionized Water may leak.) (Attention: Do not touch filter media with bare hands.)



Hose Clamp  
(463-089)

Distilled or  
Deionized  
Water Filter  
Assembly  
(687-0990)

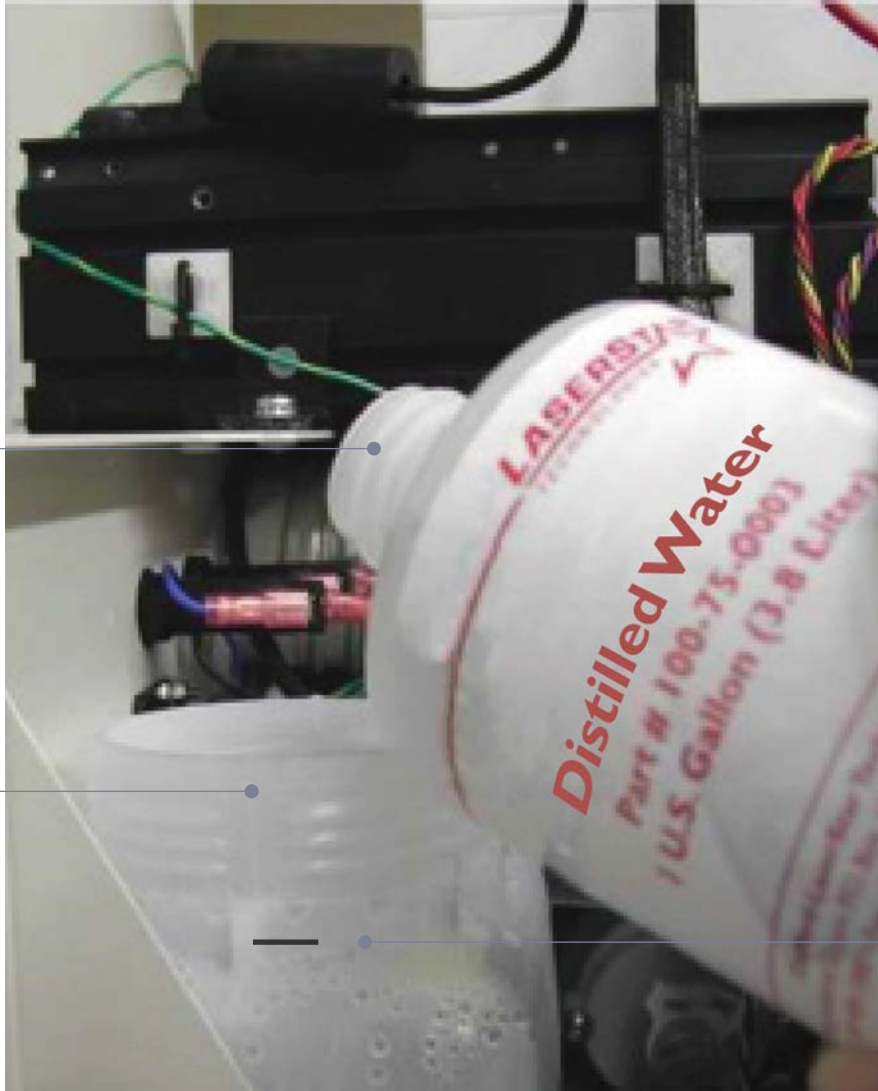
**Figure 6**  
(Distilled or Deionized Water  
Bottle Cap with Filter Removed)

### IX. Service, Figures and Parts Labeling Continued on Next Page

## Figures and Parts Labeling (continued)

Carefully pour Distilled or Deionized Water into Distilled or Deionized Water Bottle. Make sure no Distilled or Deionized Water gets on the electronics.

Distilled or Deionized Water Bottle



Fill the Distilled or Deionized Water Bottle to the blackline (filter out). This is the “Maximum Fill Line: Filter Out”.

**Figure 7**  
(Distilled or Deionized Water Bottle Being Filled)

**IX. Service, Figures and Parts Labeling Continued on Next Page**

## Figures and Parts Labeling (continued)

Re-install the Distilled or Deionized Water Filter Assembly & screw on the Twist Cap. Twist Cap should be tightened by hand.



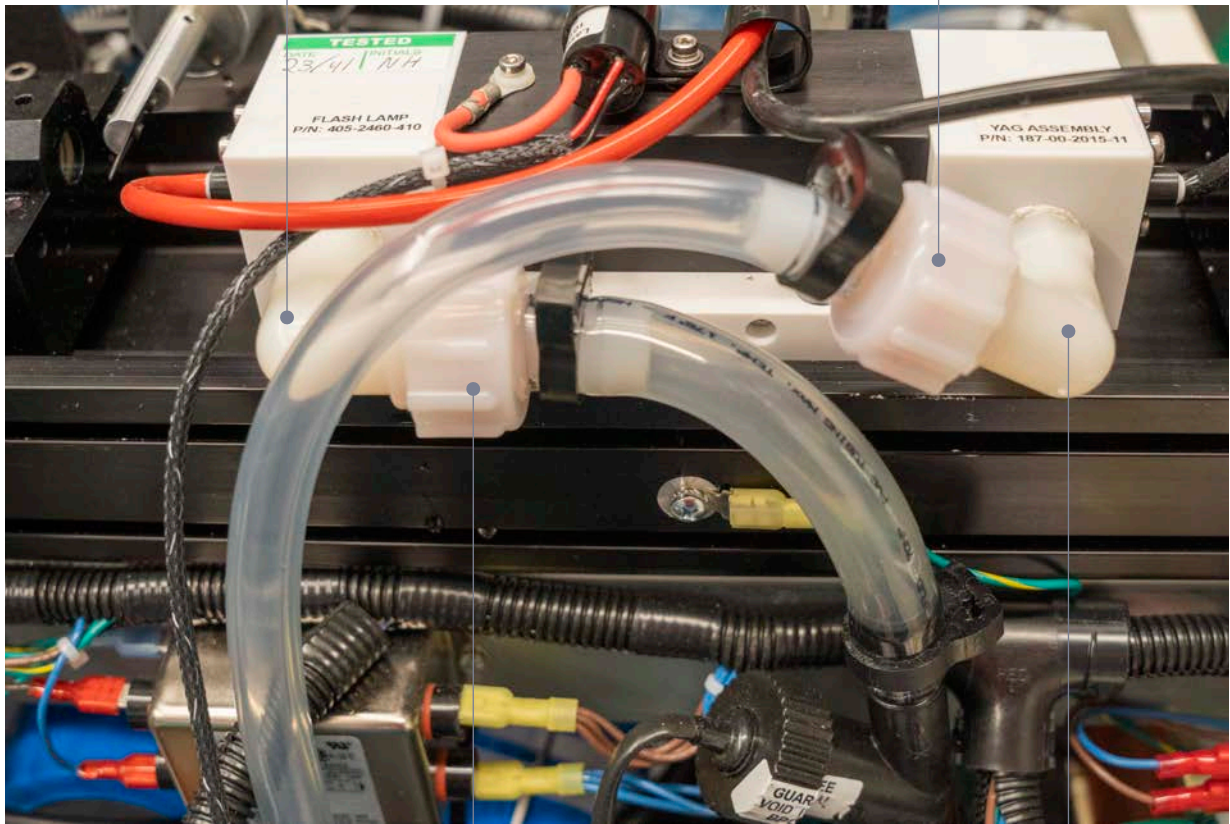
**Figure 8**  
(Distilled or Deionized Water Bottle  
Filter & Cap Installed)

### IX. Service, Figures and Parts Labeling Continued on Next Page

## Figures and Parts Labeling (continued)

Front Pump Chamber; Inlet

Rear Cooling Hose; Outlet



**Figure 9**  
**(Pump Chamber Assembly Cooling Hose Connections)**

Front Cooling Hose; Inlet

Rear Pump Chamber; Outlet

### IX. Service, Figures and Parts Labeling Continued on Next Page

## Service B: Flashlamp Replacement

### Tools (supplied or required):

- #2 Phillips Screwdriver & 3/16" Slotted Screwdriver
- 1.5 – 6mm Hex Key Wrench Set (metric)
- 70% Isopropyl Alcohol (flammable substance; be sure to use caution when applying), other approved optical cleaner or our recommended product, LaserStar Technologies Corporation® Optical Cleaning Solution (part number: 810-2353).
- Siphon Hose, Basting Bulb (with 6" spout; McMaster-Carr-#7656K3) or Water Pump (manual or battery-powered)
- Clean Plastic Bucket or Container (≥6 liters or 1.5 gallons)
- Lint-free cloth or our recommended solution, LaserStar Technologies Corporation® Cleaning Cloth (part number: 810-2356 [quantity: 1]) or 810-2354 [quantity: 90].
- Absorbent Paper Towels or Shop Towels (i.e. Scott Shop Original)
- Disposable Vinyl or PVC Gloves (powder-free and DEHP & DOP-free)
- Small Funnel
- Distilled or Deionized Water
- Clean Room or Workspace

(Note: The flashlamp replacement kit includes the flashlamp, O-rings, lab-quality gloves, protective tubing, and detailed steps and instructions for replacement. **(Attention: When replacing the flashlamp, be sure to reference the operation manual; this is a requirement.)**)



Caution!

**When replacing the flashlamp, be sure to wear protective eyewear and gloves; do not handle the flashlamp unless you are wearing lab-quality gloves.**

1. Prior to removing the machine's rear cover, turn "off" the **key switch** and **mains power switch**; unplug the AC power cord from both the machine and wall outlet.
2. Wait thirty (30) minutes. (This allows the flashlamp power supply to fully discharge.)
3. Remove machine rear cover by removing the screws located on the rear of the cover as shown in (Figure 1). Carefully slide the cover back and remove the ground wire/green with a yellow stripe.

## IX. Service, Section B: Flashlamp Replacement Continued on Next Page

## Service B: Flashlamp Replacement (continued)

The machine's water bottle must be  $\leq \frac{1}{2}$  full before replacing the flashlamp. Proceed to the start of the Service section and choose the appropriate section for servicing. (Note: Taking some water out of the bottle allows space for the water in the Pump Chamber to drain when the flashlamp o-ring seal is broken.)

4. Once the distilled or deionized water in the bottle is at the correct level, turn the machine so the right side is facing you. the laser rail orientation for flashlamp replacement is shown in (figure 2). The technician replacing the flashlamp will be facing the laser rail from the side with the cooling water hoses / tubing. (Note: The microscope will be at your left. Place a clean cloth on the top of the right side panel to prevent scratching the paint & have a roll of paper towels available to wipe up any water that leaks out of the fittings.)
5. Proceed with flashlamp replacement steps (7-27) with applicable figures 1-21 to replace the flashlamp.

**Attention:** These replacement steps are applicable for a flashlamp that is not broken or shattered. If shattered or broken, proceed to next page "attention" for directions.



**Attention:** Verify that the water bottle has been lowered to the minimum level line before starting the flashlamp replacement procedure.



**Attention:** If the flashlamp is broken / shattered, the "iWeld Laser Pump Chamber Repair Instructions" must be followed. The repair instructions are available on a USB Flash Drive / 987-99991-187, which is included in the O-ring Replacement Kit / (187-00-025). The O-ring replacement kit is required when disassembling and rebuilding a laser pump chamber. O-rings must not be reused. The "iWeld Laser Pump Chamber Repair Instructions" / (87-99990-187 are available at [laserstar.net](http://laserstar.net). (Note: Please contact LaserStar Technologies Corporation® Service Department for repair guidance on the pump chamber assembly / 187-00-1001 components. Components kits include flashlamps, laser rod assembly, flow plate, O-rings, etc. The service department will assist in ordering the correct replacement kits.)

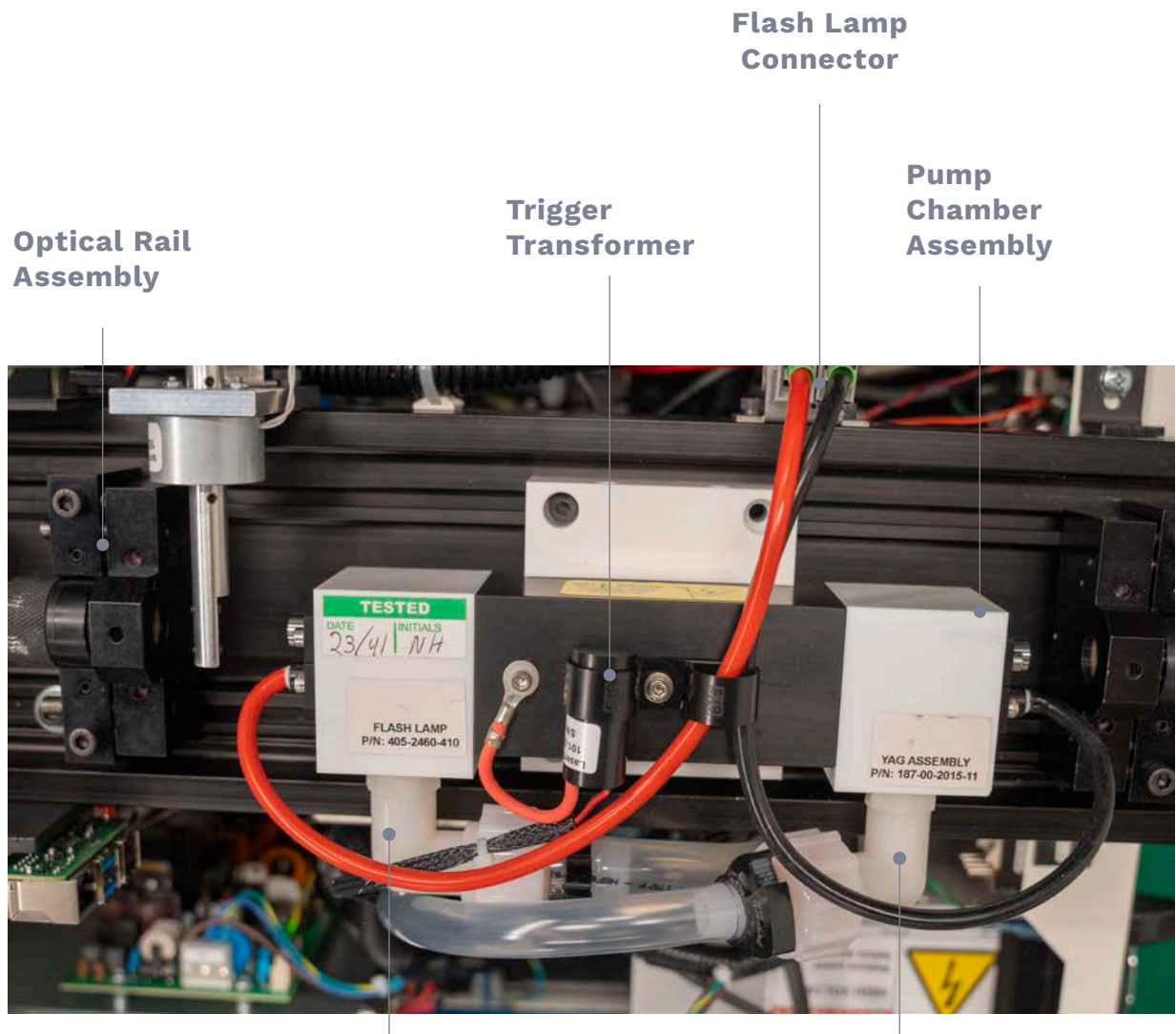


Caution!

**Wear eye protection and protective gloves! Do not handle the flashlamp unless you are wearing lab quality gloves.**

## IX. Service, Section B: Flashlamp Replacement Continued on Next Page

## IX. Service B: Flashlamp Replacement (continued)



**Figure 1**  
(Optical Rail)

**Front Cooling  
Hose**

**Front Cooling  
Hose (tubing  
fitting)**

**IX. Service B: Flashlamp Replacement Continued on Next Page**

## Service B: Flashlamp Replacement (continued)

6. Disconnect flashlamp wires and trigger transformer connector **(figure 2a & 2b)**.
7. Place paper towels below the two (2) hose fittings **(figure 3)**. **(Attention: Be sure not to disconnect either of the hose fittings at this time.)**
8. Remove the two (2) screws securing the pump chamber assembly to the rail **(figure 4)**.
9. Carefully lift the rear of the chamber and slowly disconnect the rear hose fitting; wait 10 seconds to allow the remaining water in the pump chamber to drain; level the pump chamber and then disconnect the front hose fitting. Next, immediately rotate the chamber with the hose fittings facing upward **(figure 5)**. **(Attention: Keep a small bucket nearby to empty any remaining water from the pump chamber. Make sure also to have paper towels available to wipe spilled water.)**
10. Place pump chamber on a clean benchtop or desk; remove flashlamp wires from cable clamp and straighten **(figure 6)**.
11. Rotate pump chamber so that the black wire is facing outward and remove end cap screws and end cap using a M 2.5 Hex Key Wrench **(figure 7)**.
12. Rotate pump chamber; red wire facing outward; remove the end cap screws and end cap; and then gently pull on the red wire until the O-ring can be removed from the flashlamp and then discard the O-ring **(figure 8)**. **(Attention: Do not remove the flashlamp out at this time.)**
13. Rotate pump chamber so that the black wire end is on the right; remove the o-ring and discard the o-ring. Install the protective tube over the red wire end and make sure the metal connector is covered and not protruding. Carefully feed the protective tube covering the red flashlamp wire through the pump chamber while pulling on the black wire. (Note: The protective tube should remain in the chamber **(figure 9)**. **(Attention: If the flashlamp is broken or shattered, before continuing, be sure to reference “Attention” on page 107. Discard the flashlamp per applicable regulations.)**)
14. Remove the new flashlamp assembly from the box and straighten the red and black wire. **(Attention: Make sure the protective tube is installed in the pump chamber as shown to protect the flow plate.)** Feed the red wire thru the right pump chamber end block as shown. Next, pull on the red wire and protective tube together until the flashlamp black plastic end is visible and extended approximately equal on both ends **(figure 10)**. **(Note: The protective tube can now be removed from the red wire end of the flashlamp assembly.)**

## IX. Service, Section B: Flashlamp Replacement Continued on Next Page

## Service B: Flashlamp Replacement (continued)

15. Install a new o-ring on both ends of the flashlamp assembly **(figure 11)**.
16. Install end caps with screws on both ends of the Pump Chamber Assembly **(figure 12)**.  
**(Attention: Do not tighten screws at this time.)**
17. Position the flashlamp assembly such that each end of the flashlamp (plastic body/insulator) extends equally on both ends of the pump chamber **(figure 13)**.
18. Tighten the end cap screws on both ends of the pump chamber assembly and verify that each end of the flashlamp extends equally. (Note: Red wire end shown). Next, place the wires back through the cable clamp **(figure 14)**.
19. Carefully place the pump chamber back into the laser rail **(figure15)**. **(Attention: Be careful not to bump the rear mirror assembly.)**
20. Position the pump chamber against the rail reference edge and then the end stop. Before tightening the pump chamber screws, move the pump chamber forward off the end stop by ~0.01" and then use an M4 hex key wrench to tighten the (2) screws evenly **(figure 16)**.
21. Connect the red and black flashlamp wires to the flashlamp rail connector **(figure 17 & 18)**.
22. Connect the trigger transformer connector **(figure 19)**.
23. Connect the water cooling hoses to the pump chamber and tighten **(figure 21)**.
24. Fill the water bottle and prime the pump, per instructions at the start of this section.
25. Re-install rear cover.

## IX. Service, Section B: Flashlamp Replacement Continued on Next Page

## IX. Service B: Flashlamp Replacement (continued)

Disconnect  
Simmer  
/ Trigger  
Transformer  
Cable at the  
Connector



**Figure 2**  
(Disconnect Flash-  
lamp Wires; Left Side  
View of Laser Rail)

**Trigger  
Transformer**

**IX. Service, Section B: Flashlamp Replacement Continued on Next Page**

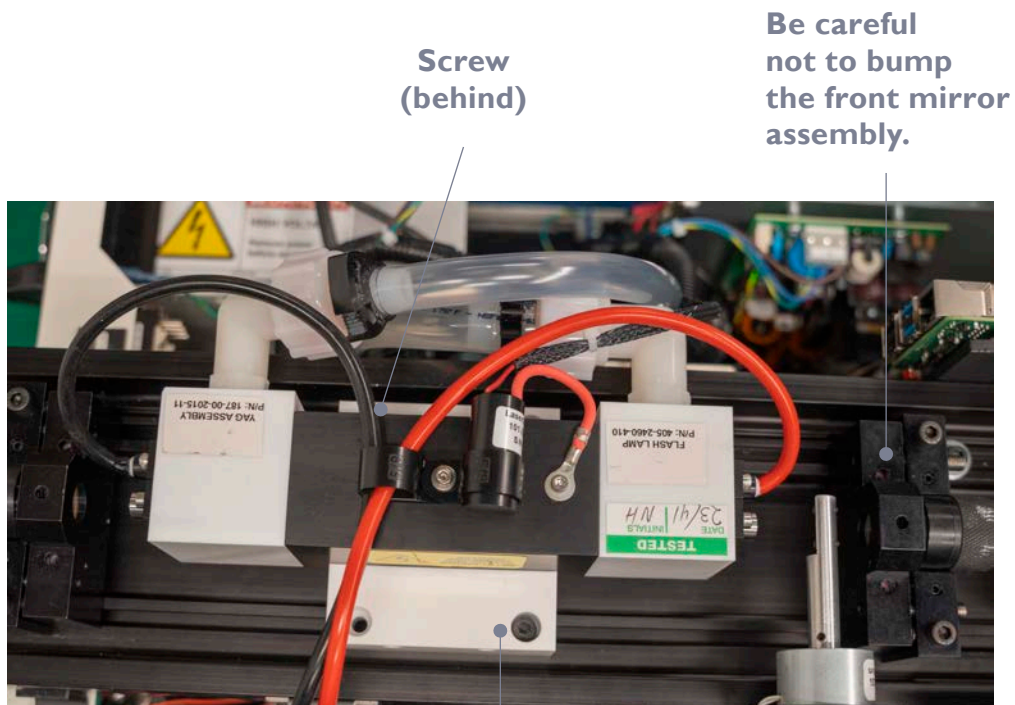
## IX. Service B: Flashlamp Replacement (continued)



**Figure 3**  
(Paper Towels)

Remove the screws from the rail retaining nuts (use an m4 hex key wrench).

**WARNING:**  
Be careful not to bump the rear mirror assembly.



**Figure 4**  
(Rail Retaining Nuts)

Screw

IX. Service, Section B: Flashlamp Replacement Continued on Next Page

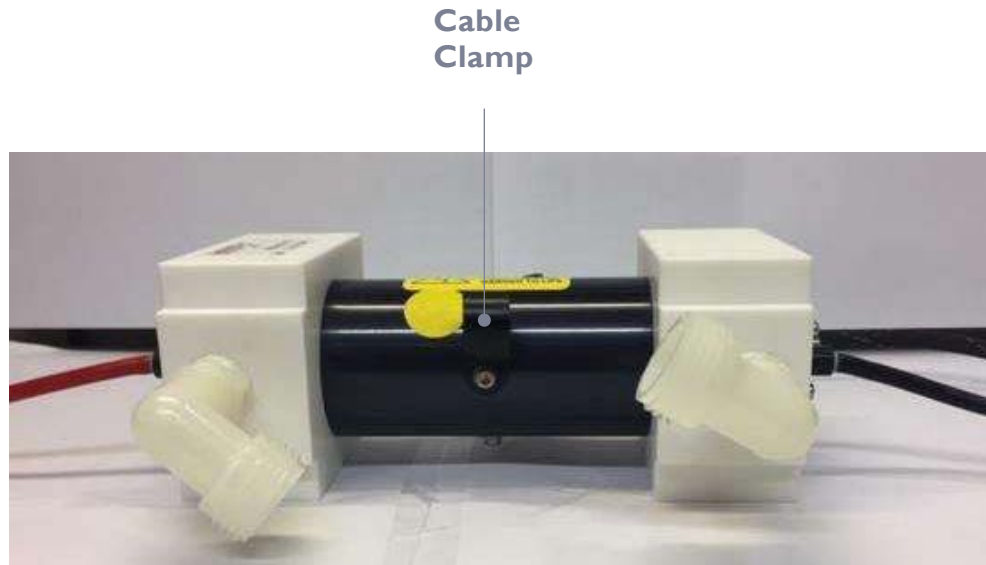
## IX. Service B: Flashlamp Replacement (continued)



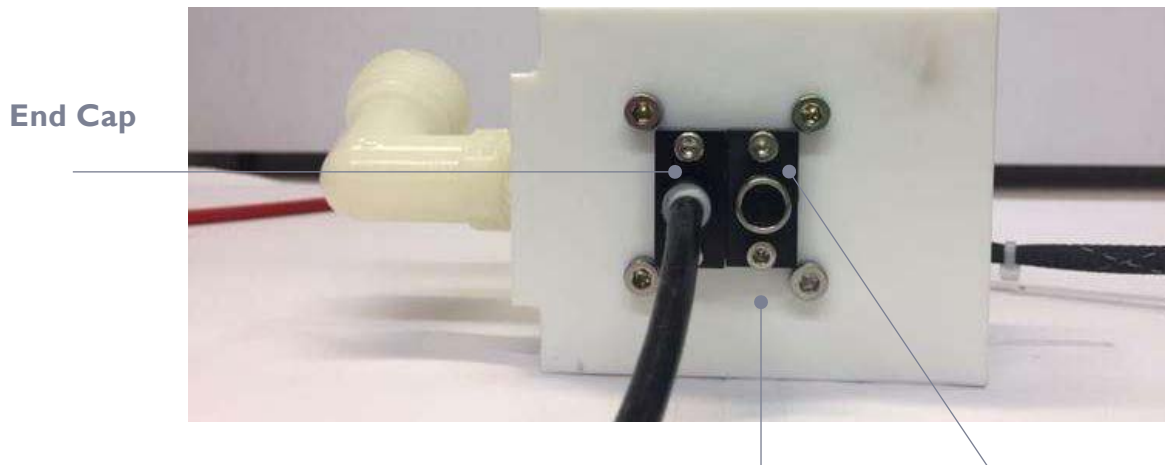
**Figure 5**  
(Pump Chamber  
[Tipping & Draining])

**IX. Service, Section B: Flashlamp Replacement Continued on Next Page**

## IX. Service B: Flashlamp Replacement (continued)



**Figure 6**  
(Pump Chamber [with  
Flashlamp Wires Removed  
from the Cable Clamp &  
Straightened])



**Figure 7**  
(End Cap & End Cap  
Screws [removal])

**End Cap  
Screw (1)  
[x4 total]**

**End Cap  
Screw (2)  
[x4 total]**

**IX. Service, Section B: Flashlamp Replacement Continued on Next Page**

## IX. Service B: Flashlamp Replacement (continued)



**Figure 8**  
(End Cap Removal  
[O-Ring Being Removed])

O-Ring

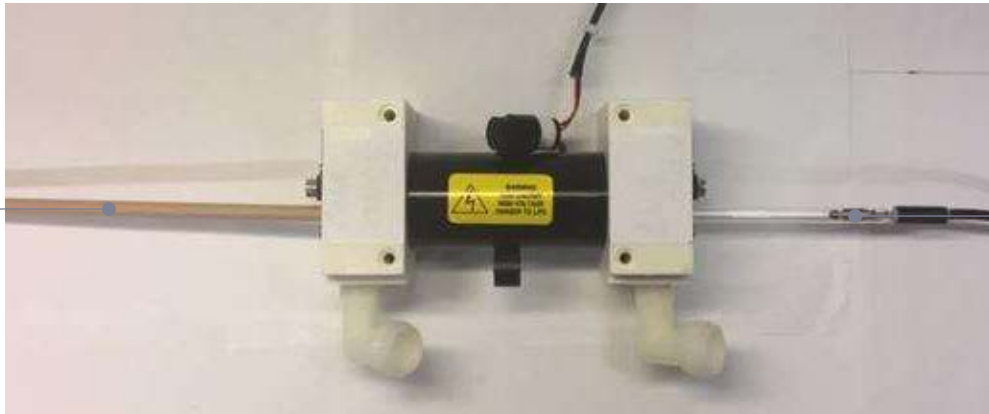
**IX. Service, Section B: Flashlamp Replacement Continued on Next Page**

## IX. Service B: Flashlamp Replacement (continued)



**Wear eye protection and protective gloves! Do not handle the flashlamp assembly or laser rod assembly unless you are wearing lab quality gloves.**

Install the protective tubing over the flashlamp (red-wired end), making sure the metal connector is covered and not protruding.



Flashlamp

**Figure 9**  
(Flashlamp [removal])

**IX. Service, Section B: Flashlamp Replacement Continued on Next Page**

## IX. Service B: Flashlamp Replacement (continued)



**Figure 10**  
(Flashlamp Installation  
[with Protective Tubing  
& Plastic Ends Equally  
Extended])

**IX. Service, Section B: Flashlamp Replacement Continued on Next Page**

## IX. Service B: Flashlamp Replacement (continued)

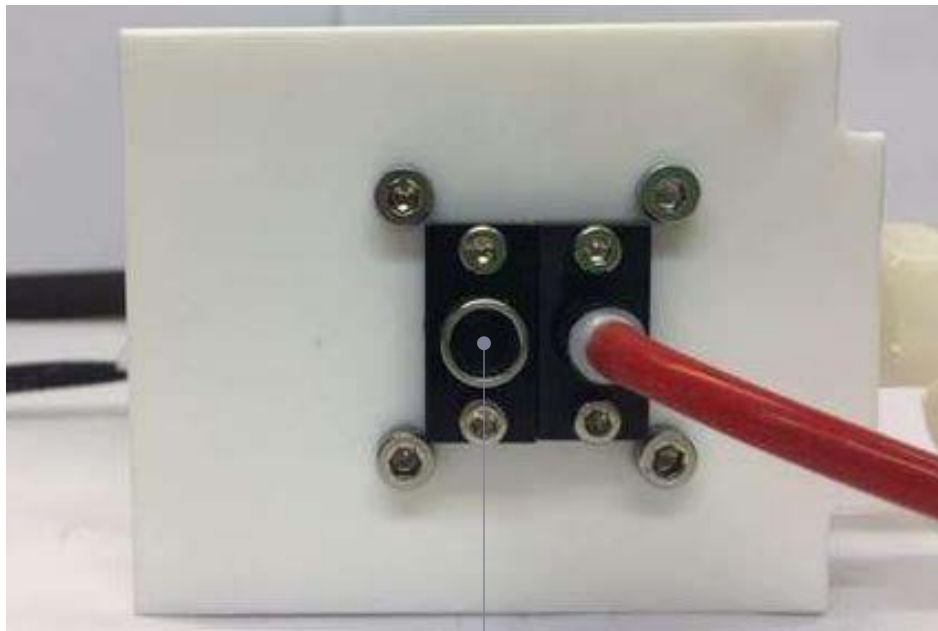


**Figure II**  
(O-Ring [new  
installation])

O-Ring

**IX. Service, Section B: Flashlamp Replacement Continued on Next Page**

## IX. Service B: Flashlamp Replacement (continued)



**Figure 12**  
(Red-wired End Cap  
Installation [Repeat for  
Black-wired End Cap])

**Installing  
End Caps**

**IX. Service, Section B: Flashlamp Replacement Continued on Next Page**

## IX. Service B: Flashlamp Replacement (continued)

Flashlamp  
(extends out  
the same amount  
on each end)

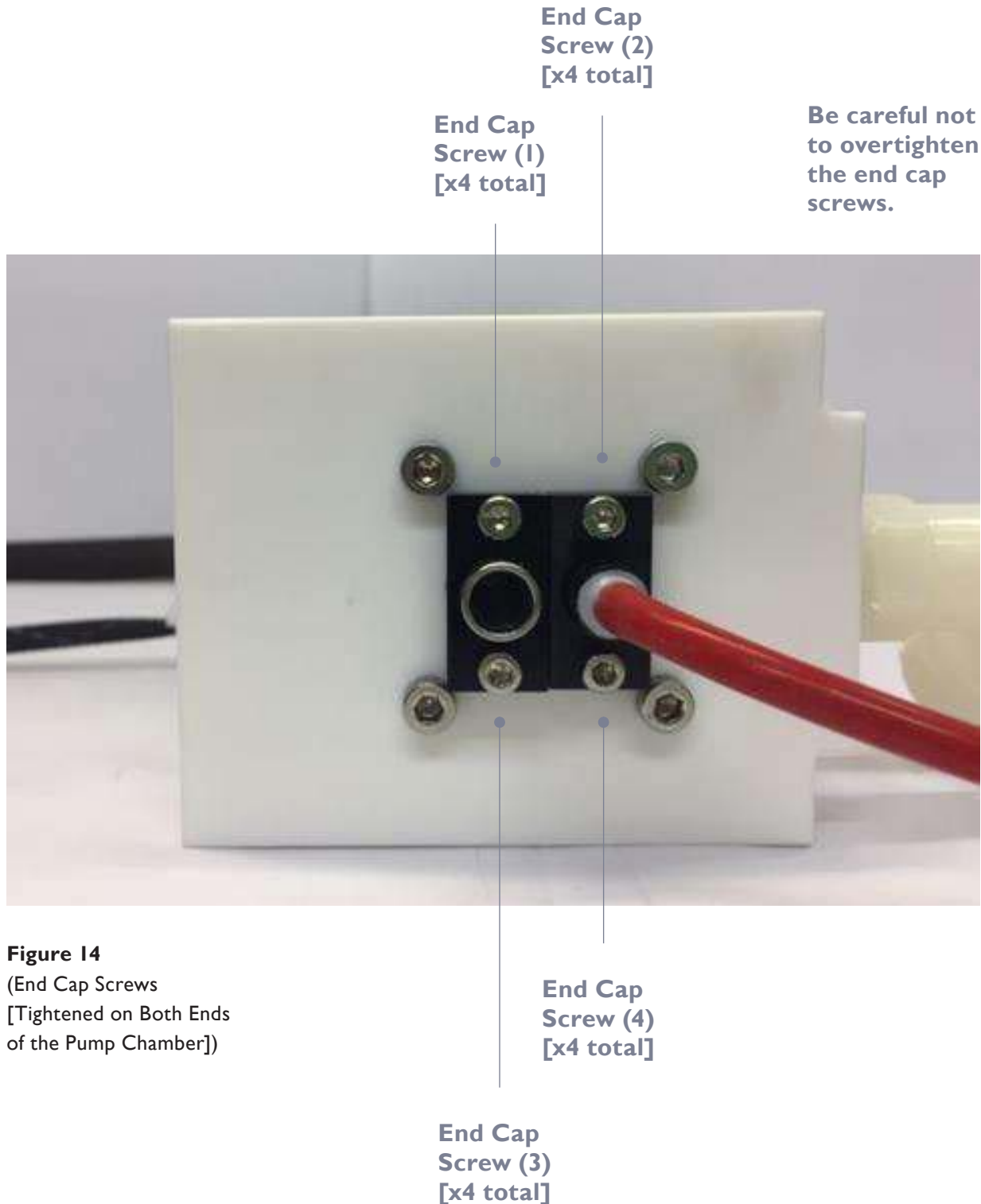
Flashlamp  
(extends out  
the same amount  
on each end)



**Figure 13**  
(Flashlamp [installed])

**IX. Service, Section B: Flashlamp Replacement Continued on Next Page**

## IX. Service B: Flashlamp Replacement (continued)



**Figure 14**  
(End Cap Screws  
[Tightened on Both Ends  
of the Pump Chamber])

**IX. Service, Section B: Flashlamp Replacement Continued on Next Page**

## IX. Service B: Flashlamp Replacement (continued)

Remove the screws from the rail retaining nuts (use an m4 hex key wrench).

**WARNING:**  
Be careful not to bump the rear mirror assembly.



**Figure 15**  
Pump Chamber [Installation]  
& Fastening the Screws to the  
Optical Rail)

**(Note: Carefully place the Pump Chamber Assembly back into the Optical Rail Assembly (the component should rest against the End Stop). When mounting the Pump Chamber to the Optical Rail, locate the retaining nut (on the rail) and replace each of the screws one at a time. This may take a few tries—be patient. Be sure not to fully tighten the screws at this point.)**

**IX. Service, Section B: Flashlamp Replacement Continued on Next Page**

## IX. Service B: Flashlamp Replacement (continued)

I. Push the Pump Chamber back against the End Stop. Next, move off the End Stop [by ~.010”].

2. Tighten the two Pump Chamber screws using an M4 hex key wrench.



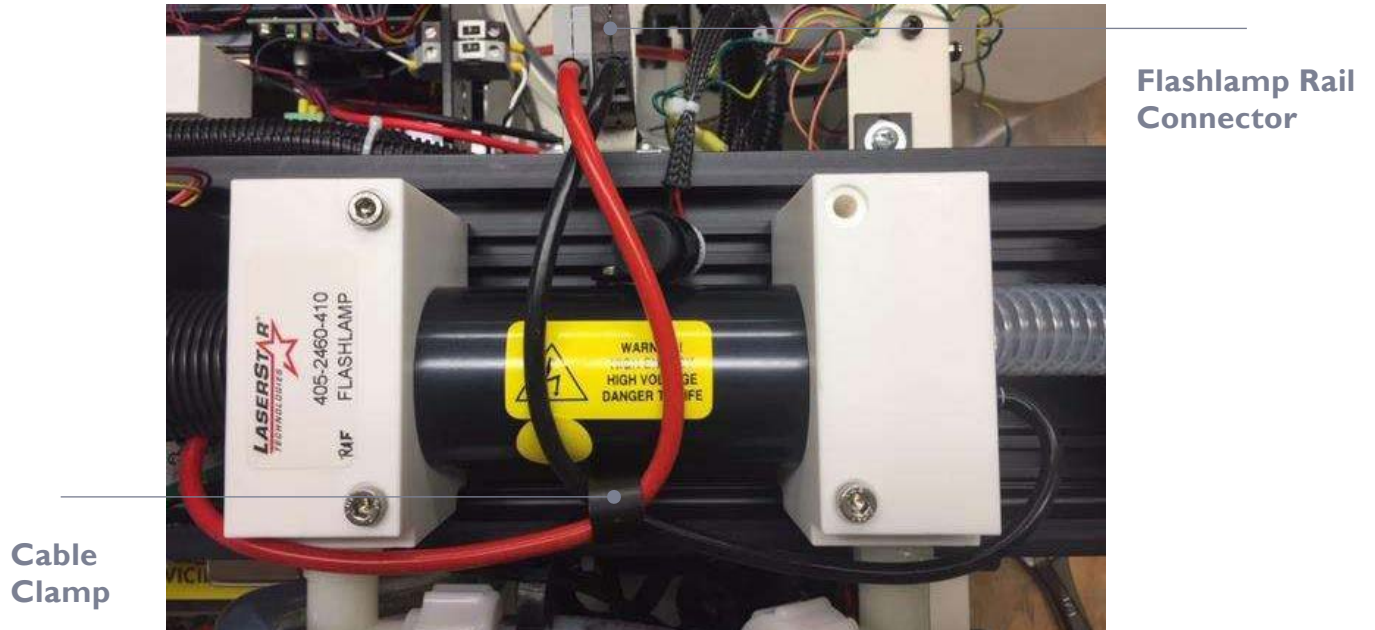
**Figure 16**  
(Pump Chamber [Positioning the Assembly Against the End Stop & Optical Rail Reference Edge])

Make sure the Pump Chamber is resting flat on the rail surface.

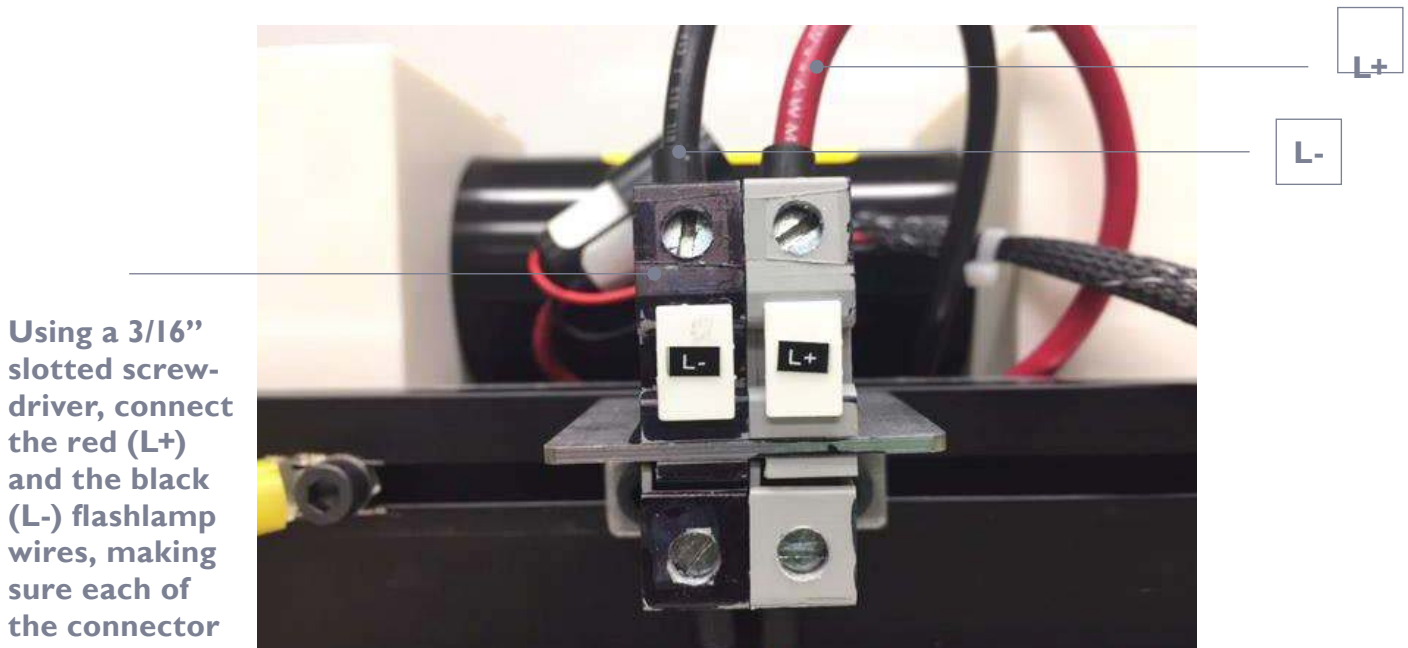
End Stop (hidden from view)

IX. Service, Section B: Flashlamp Replacement Continued on Next Page

## IX. Service B: Flashlamp Replacement (continued)



**Figure 17**  
(Flashlamp [Wires Connected])



Using a 3/16" slotted screwdriver, connect the red (L+) and the black (L-) flashlamp wires, making sure each of the connector screws are securely fastened.

**Figure 18**  
(Flashlamp Wires; [Optical Rail; left-side])

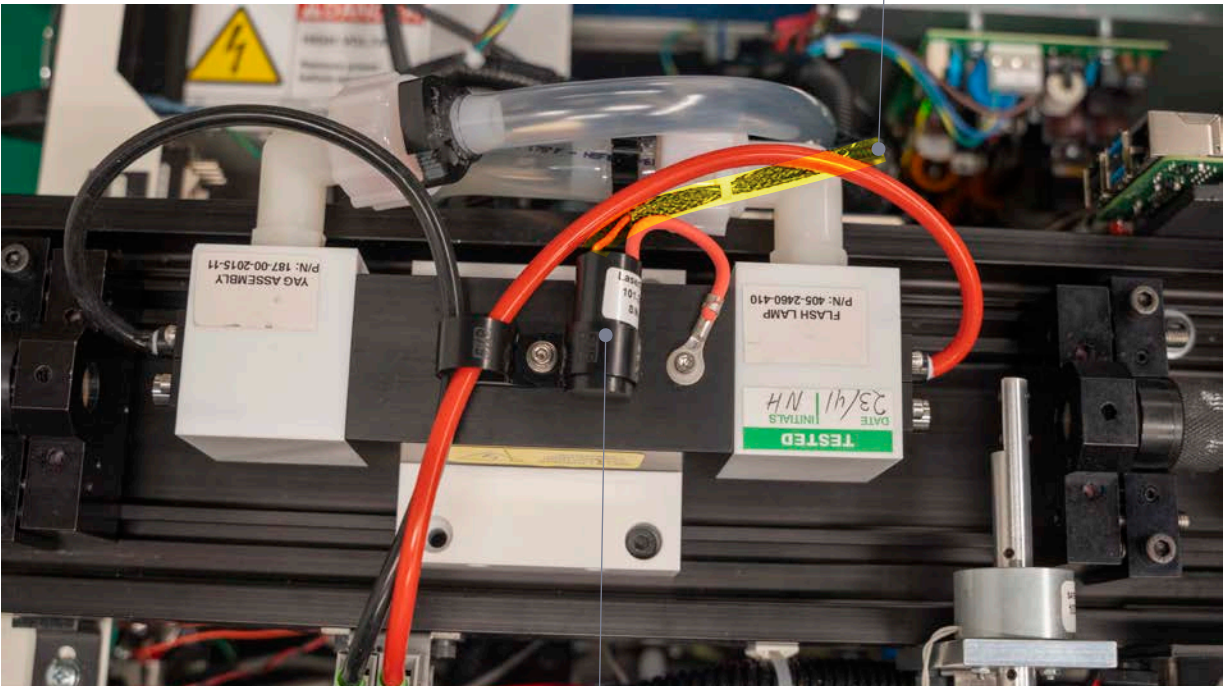
**IX. Service, Section B: Flashlamp Replacement Continued on Next Page**

## IX. Service B: Flashlamp Replacement (continued)



**Attention:** Verify the (L+) / RED wire and (L-) / BLACK wire are connected correctly. A lamp installed with reverse polarity will age after just a few pulses, causing rapid loss of laser power and any contamination on the lamp surface will dramatically shorten the lamp's life.

Trigger  
Transformer  
Connector



**Figure 19**  
(Trigger Transformer  
Connector)

Trigger  
Transformer

**IX. Service, Section B: Flashlamp Replacement Continued on Next Page**

## IX. Service B: Flashlamp Replacement (continued)



**Figure 20**  
(Connect & Tighten  
the Hose Fittings  
[x2 total])



Caution!

**Do not start the system if any water gets on the electronics. Let system dry for 24-hours. Immediately remove spilled water by dabbing it with a paper towel or lint-free rag. If not dry, call LaserStar Technologies Corporation® Service Department for instructions.**



**While bleeding the system, verify that there are no Pump Chamber leaks around the flashlamp O-ring seals and pump chamber hose connections.**

In the interest of safe and faultless operation of the product, it is strongly recommended that you keep a logbook for each laser, such as the one detailed in [Appendix Section C \(Pages 181-182\)](#). In this logbook all malfunctions and extraordinary events as well as all service and maintenance activities should be entered (e.g. replacement of the lamp or the filter).

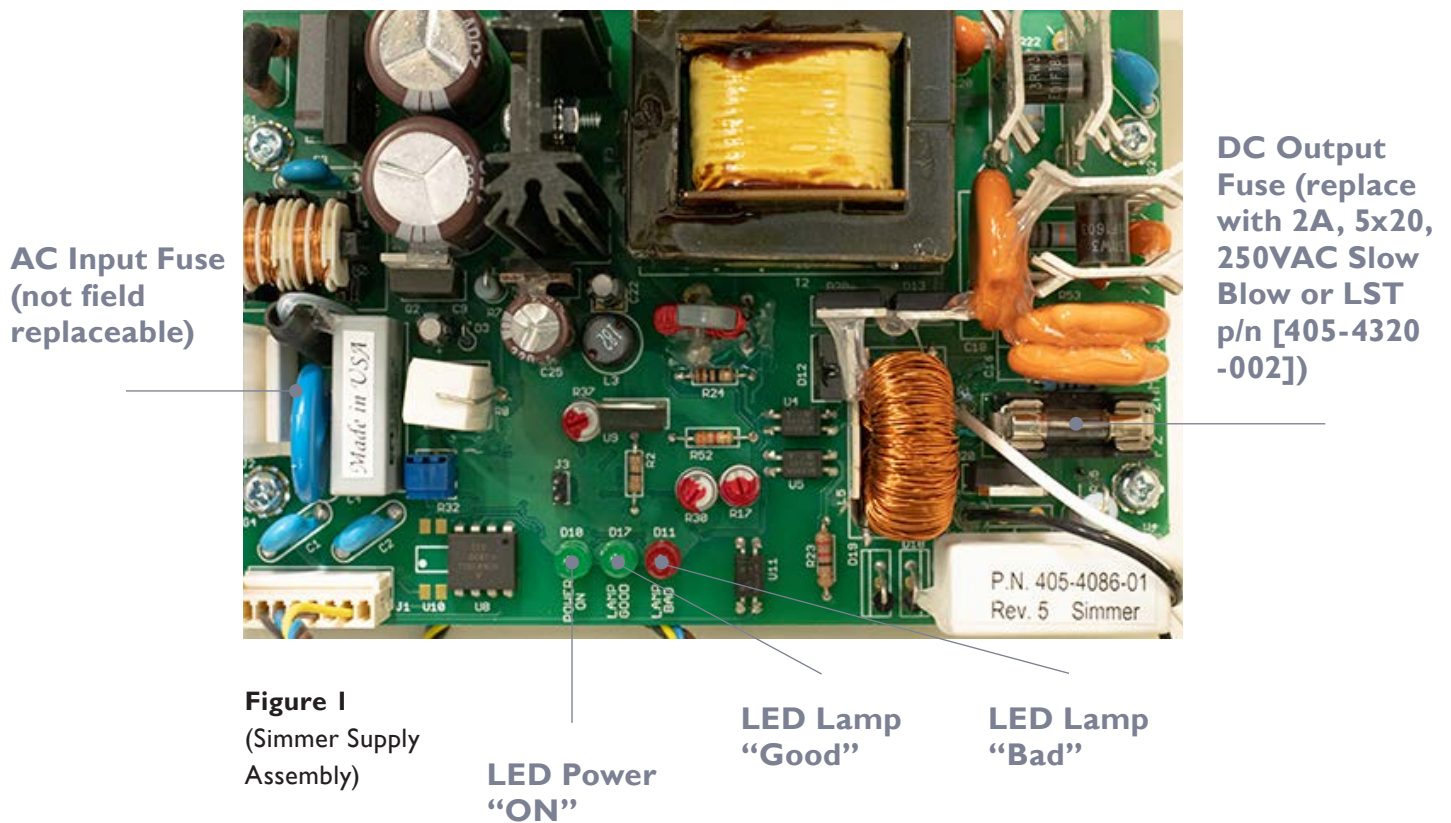
## Service C: Simmer Supply

(Note: Reference Service section / Major System Components for the simmer location for the specific machine model / series location.)

The following LED Indicators can be used to indicate the status of the AC Simmer Board Assembly and the status of the Flashlamp. Led Indicators:

- Power On Led (top)- Green “on”-Simmer board powered up
- Lamp Good Led (middle)-Green “on”-Lamp okay
- Lamp Bad Led (bottom)-Red “on”-Lamp not okay

### AC Simmer Circuit Board Assembly



**Figure 1**  
(Simmer Supply Assembly)

**(Note: All measurements taken across the flashlamp contacts with a voltmeter set to a range greater than 1000 VDC.)**

**Lamp Good LED:** For output voltage between ~40V and ~300V the Lamp Good Indicator is ON and the Lamp Bad Indicator is OFF.

**Lamp Bad LED:** For output voltage above ~300V the Lamp Bad Indicator is ON and the Lamp Good Indicator is off. For an output voltage below ~40V the Lamp Bad Indicator is ON and the Lamp Good Indicator is OFF.

## Service D: Cap Charging Supplies

Power Indicator  
(power “ON”  
[green light lit]  
power “OFF”  
[green light off])

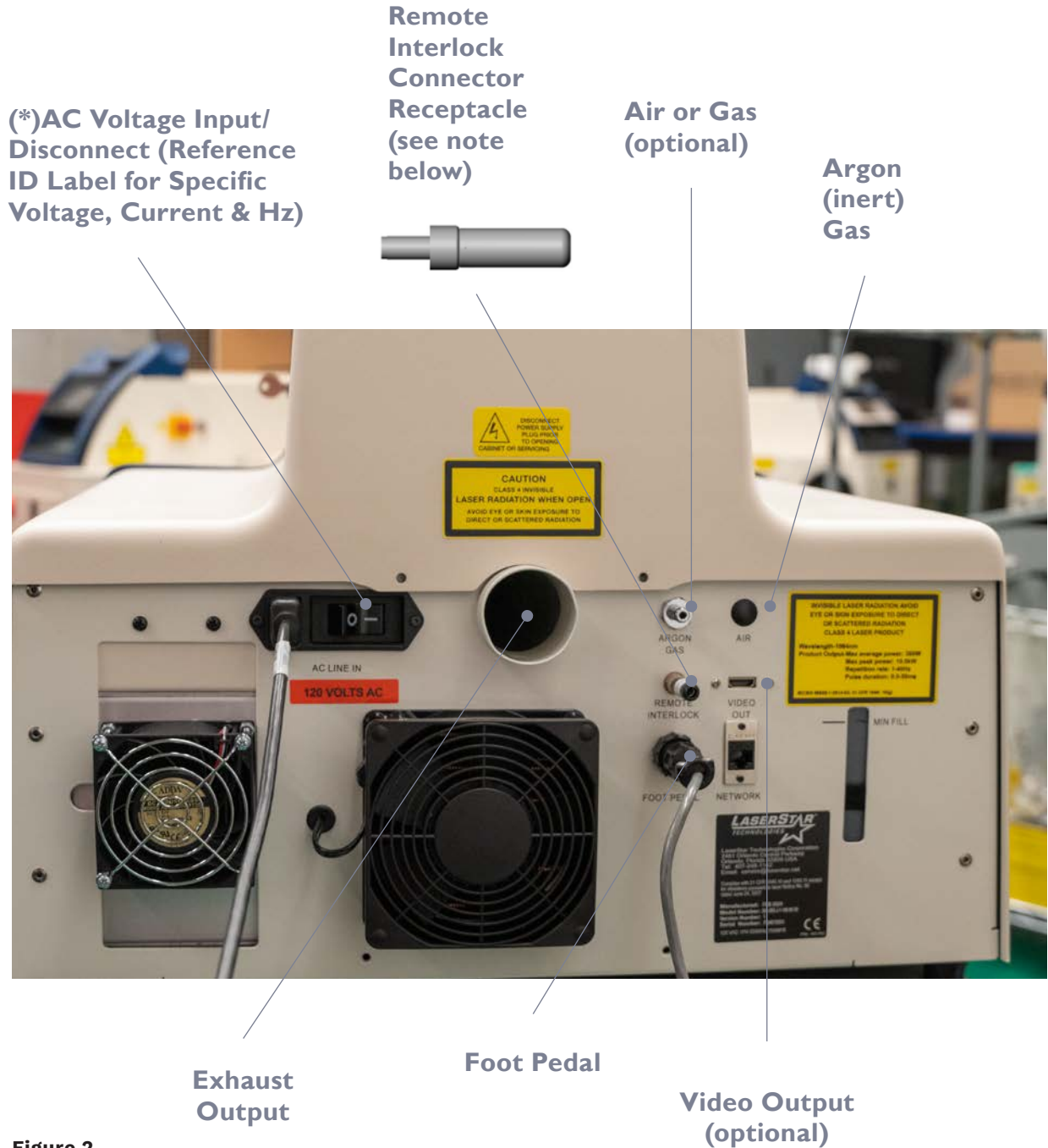


**Figure 1**

(Cap Charger [single-supply:  
120VAC or 220 & 230VAC])

**(Note: There are four (4) basic configurations for the cap charging supplies. If the indicator light is not “ON” and green, the unit is not powered up or is not operating correctly.)**

## Service E: Rear System Overview, and External Connections



**Figure 2**  
(Rear View:  
Connections)

(\*)Caution: Check the VAC label & ID label on the rear of the machine and compare with the power conditions at the installation site. (\*\*) Image of the Remote Interlock Connector that is installed in the input.

## Service F: Major Internal System Components



**Figure I**  
(Right Side-Power)

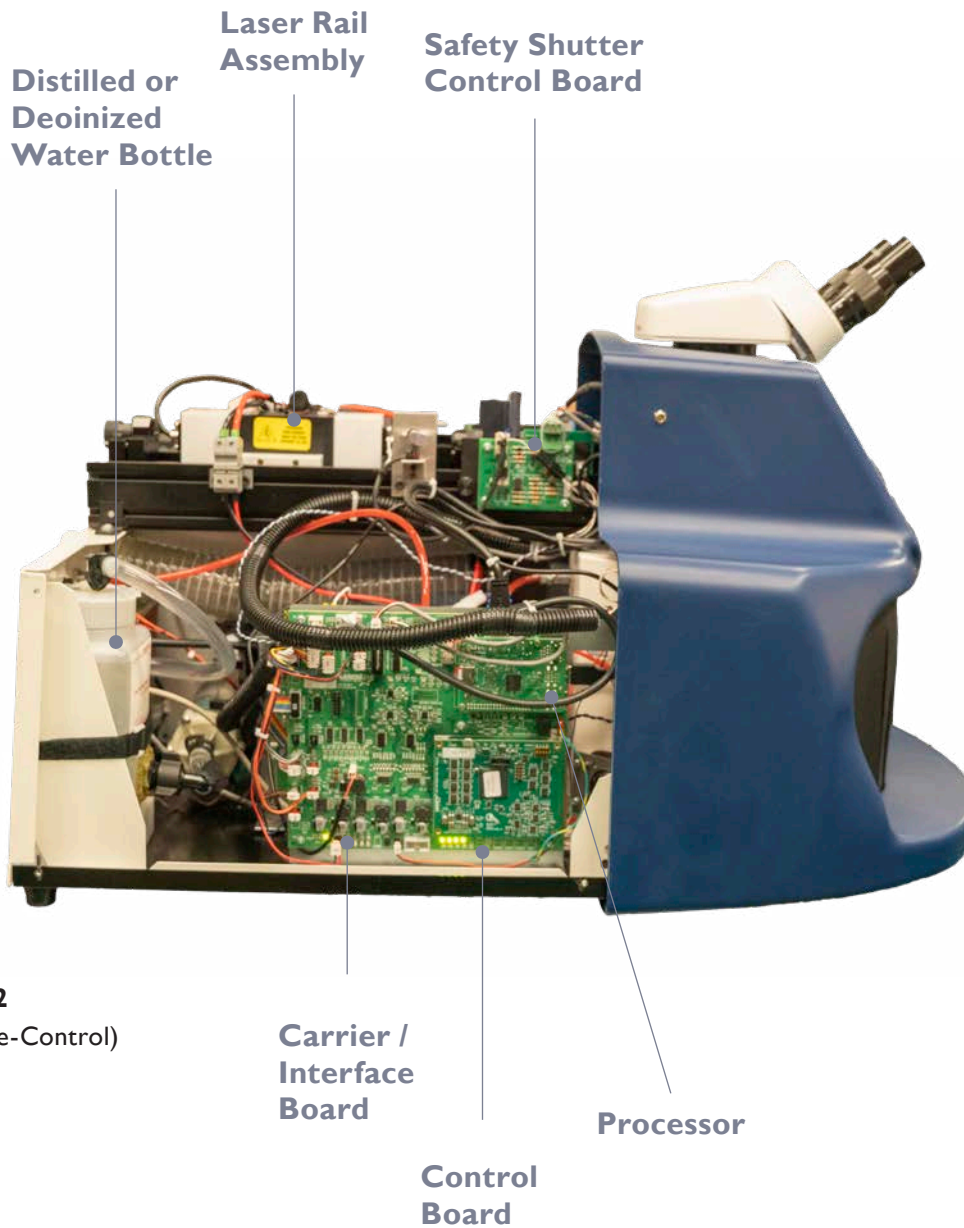
**AC Simmer  
Supply (behind  
24VDC Power  
Supply)**

**Power Supply  
24VDC**

**Cap Charging  
Supply (Note:  
AC Voltage)**

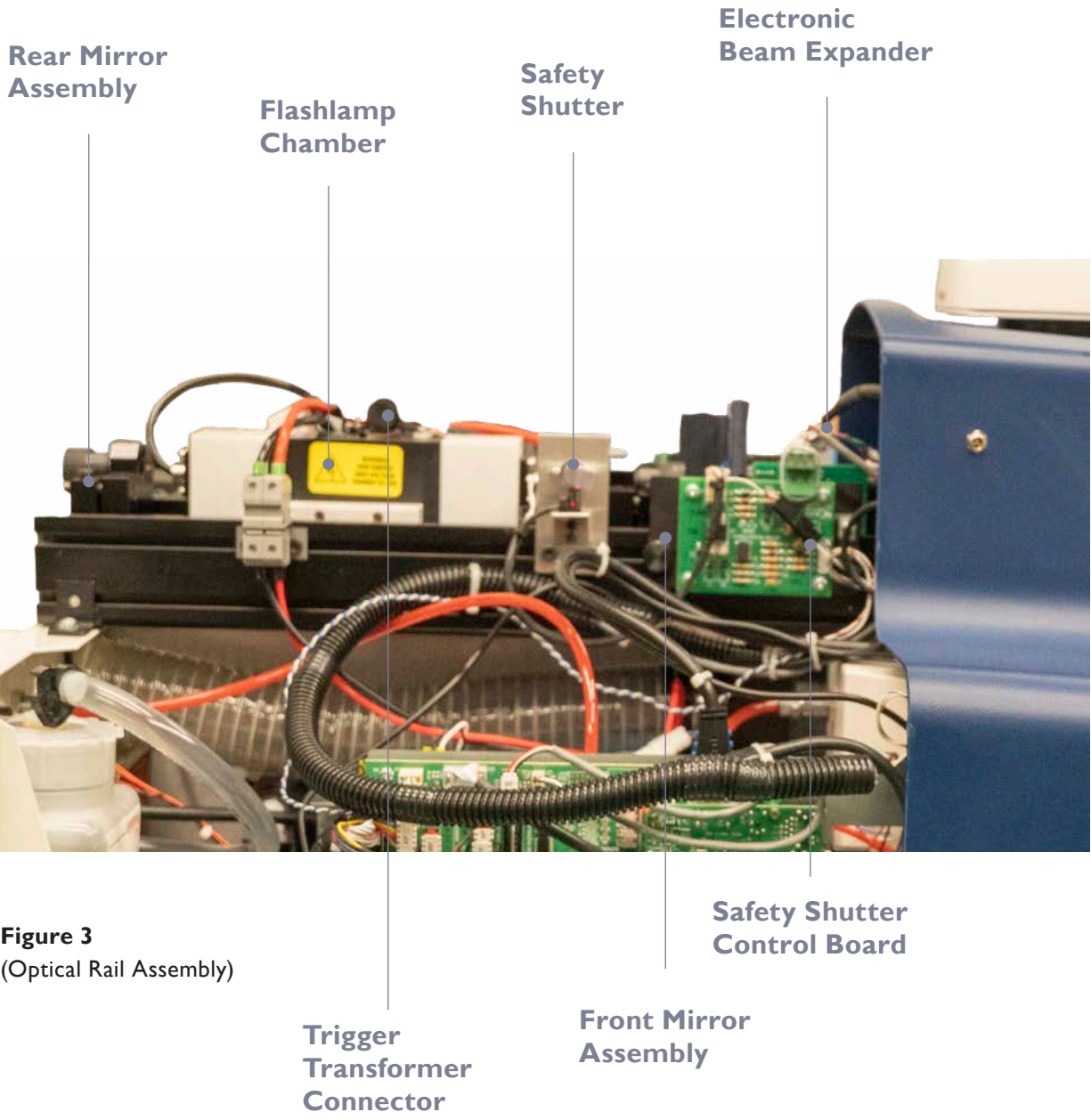
### **IX. Service F: Major Internal System Components Continued on Next Page**

## IX. Service F: Major Internal System Components (continued)



## IX. Service F: Major Internal System Components Continued on Next Page

# IX. Service F: Major Internal System Components (continued)



**Figure 3**  
(Optical Rail Assembly)

## Service G: Securing the Welder with Brackets

Brackets for securing the welder to a tabletop. (Note: Bracket screws / 5mmx12mm / LST#88-56881-512 are installed in all iWeld models prior to shipment.)



**Figure 1**  
(Securing to a  
Tabletop)

**Tabletop Bracket**  
**[12-66110]**

**(Note: Use an 8mm (or 5/16") socket wrench for the 5mm x 12mm screws (#10 32 x .375" screws may also be substituted for the 5mm screws).**

## X. Appendix

### Appendix A: Single Joystick Configuration, Controls & Operation

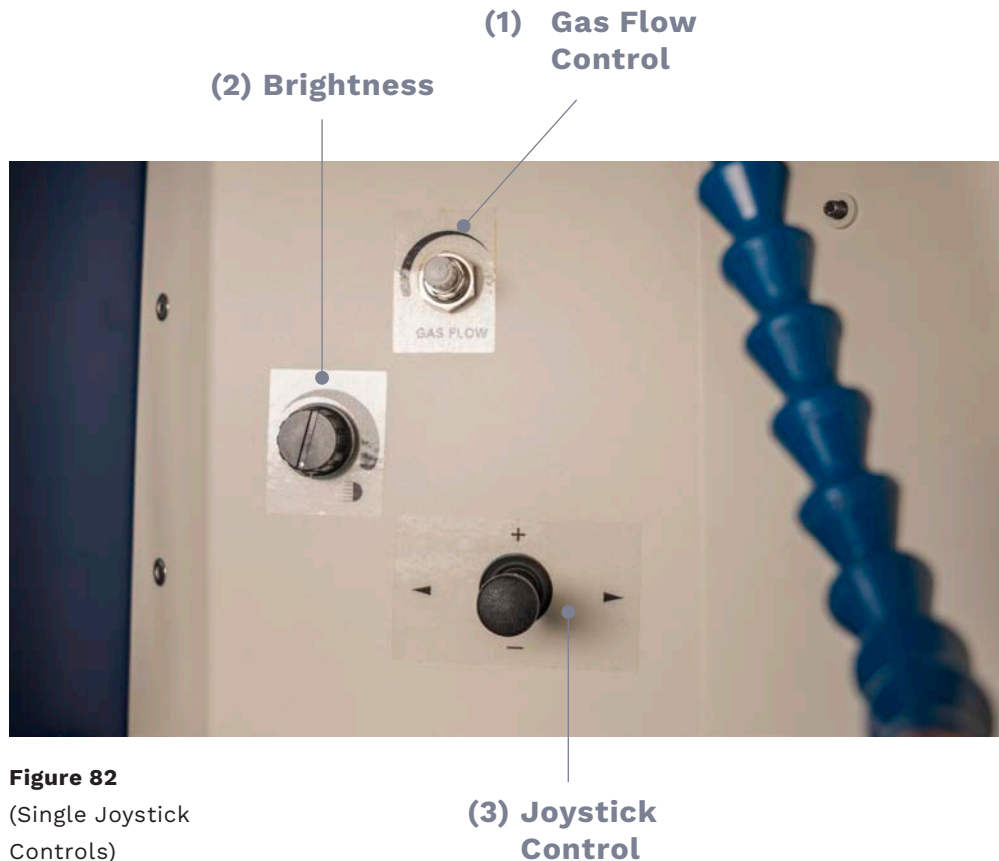
On the rear wall of the welding chamber are the **rotary argon (inert) gas flow control (1)**, **rotary brightness control (2)**, and **joystick (3)**; these control elements are used to adjust the laser pulse intensity, pulse length, and other similar factors.

#### Setting Operating Parameters

**+/-:** When the joystick is moved **up (+)**, this will increase the value for the highlighted parameter. When the joystick is moved **down (-)**, the value for the highlighted parameter is decreased.

**< (Menu):** When the joystick is moved **left**, toward the **< (Menu)** symbol, the parameter to be changed is highlighted. The parameters are highlighted in order, first **Safety Shutter** and then **Volts**. After specifying the voltage, move the joystick **right** to highlight and make selections for **PW (ms)**, **Burst**, **Hertz**, **Dia (mm)**, and finally **Pulse Shape**.

**> (Menu):** When the joystick is moved **right**, toward the **> (Menu)** symbol, the **Pulse Shape** parameter is highlighted. Moving **right** again will highlight the action buttons within the top-level of the menu. The action buttons are highlighted in order, first **Save**, followed by **Set Recipe**, and then finally the **Arrows**.



**Figure 82**  
(Single Joystick Controls)



**The machine's controller has memory recipe locations in which sets of operating parameters (each optimized for specific applications or materials) can be stored so that you can subsequently work with the same tried-and-tested operating data, enhancing both speed and efficiency, as well as your workflow process.**

## Parameter Recipes

In order to better identify and differentiate between the available memory recipe locations, the operator can assign each a unique, text-based name. Memory recipe locations are pre-programmed with default designations, but these can also be changed (refer to the section entitled: “Text-Entry Mode”).

### A stored set of parameter recipes consists of the following:

- Voltage
- Pulse Width (PW [ms])
- Burst Mode
- Hertz (single pulse [0 Hz]); (multi-pulse [≥1 Hz])
- Focus Setting (Dia [mm])
- Pulse Shape (see section on **Pulse Performance Profile [P<sup>3</sup>] Technology**)

## Resetting Stored Parameter Recipes

This function is used to restore stored or pre-programmed parameter recipes.

## Saving and Resetting Recipe Definitions

### The following are abbreviated definitions:

- S: Save, R: Reset, J: Joystick, A: Action Buttons, P: Parameter Buttons
- Action Buttons: Arrows, Set (or reset) Recipe, S: Save (current recipe)
- Parameter Buttons: O: Safety Shutter, V: Volts, PW (ms): Pulse Width, B: Burst Pulse Mode, Hz: Hertz (pulse frequency), Dia (mm): Pulse Spot Size, Pulse Shape

### The following are joystick and action button commands (with movement for context):

Joystick Left: O: Safety Shutter << Volts >> PW (ms): Pulse Width >> B: Burst Pulse Mode >> Hz: Hertz (pulse frequency) >> Dia (mm): Laser Pulse Spot Size >> Pulse Shape >> S: Save >> O: Safety Shutter

- The selected function or value will be highlighted.
- With the **arrows** highlighted, move the joystick **up** or **down** to set the value or select a mode.
- Move the joystick **left** or **right** to select the next function.

Joystick Left: O: Safety Shutter << Volts << Arrows >> Set Recipe >> S: Save >> O: Safety Shutter

- The selected function or value will be highlighted.
- With the **arrows** highlighted, move the joystick **up** or **down** to set the value or select a mode.
- Move the joystick **right** to select the next function.
- Moving the joystick **right** from the **arrows** will toggle back to **Reset Recipe** and **Save**.
- Moving the joystick **right** from the **Safety Shutter** will highlight **Save**.

**Saving and Resetting Recipe Definitions Continued on Next Page**

## Selecting or Saving Parameter Recipes

- To select a new memory recipe number, move the joystick **right**, then **left (x2)**, until the **Arrows** are highlighted.
- With the **Arrows** highlighted, move the joystick **up** or **down** to select a new memory number.
- Move the joystick **right** to **Set Recipe**; with **Set Recipe** highlighted, move **up** or **down** to set the selected recipe.
- The screen will time out and turn grey; wait for the screen to change to green.

**(Note: When saving using the joystick, make sure that you have selected a parameter recipe from within the parameter settings to be saved.)**

- To save a recipe, move the joystick **right** until **Save** is highlighted.
- Move the joystick **up** or **down**; a screen will appear with the following two (2) choices: **Save (up)** or **Cancel (down)**. Select **Save** by moving the joystick **up**.
- The screen will time out and turn grey; wait for the screen to change to green.
- The new recipe will be saved in the next available memory number.

### Notes

---

---

---

---

---

---

---

---

---

---

## Appendix B: Restricted Access & Password (PIN) Protection

**The Password feature is intended to prevent unauthorized modifications to system setups and configurations where multiple users can access the system and limits access to the Menu Screens.**

### **Changing the Password (PIN) Number:**

1. Press "MENU" on Main Screen **(Figure 1)**
2. Touch Password (Pin Number) **(Figure 4)**
3. Touch the number box (\*\*\*\*) **(Figure 2)**
4. This will bring up the numerical keypad **(Figure 3)**
5. Type in the default PIN number (9999) and press the OK button **(Figure 3)**
6. Now press (Done) **(Figure 2)**
7. Touch the number box (\*\*\*\*) **(Figure 2)**
8. Type in the new PIN number **(Figure 6)**
9. Press the OK button **(Figure 5)**
10. Uncheck No Password **(Figure 5)**
11. Now press (Done) **(Figure 4)**
12. Press Main Menu Button **(Figure 4)**
13. The new Password (PIN) is set.

**(Note: The operator can choose to enable or disable restricted access and password protection whenever they choose.)**

**X. Appendix, Section B: Restricted Access & Password (PIN) Protection Continued on Next Page**

## **No Password Checkbox:**

Selecting this option (check mark in the box) will eliminate the need to enter a password for those users who don't require a password and do not want to take the time to enter a password to go into the Menu Options.

If the "No Password" checkbox is unchecked the last password used will become the required password for entry into the Menu Options.

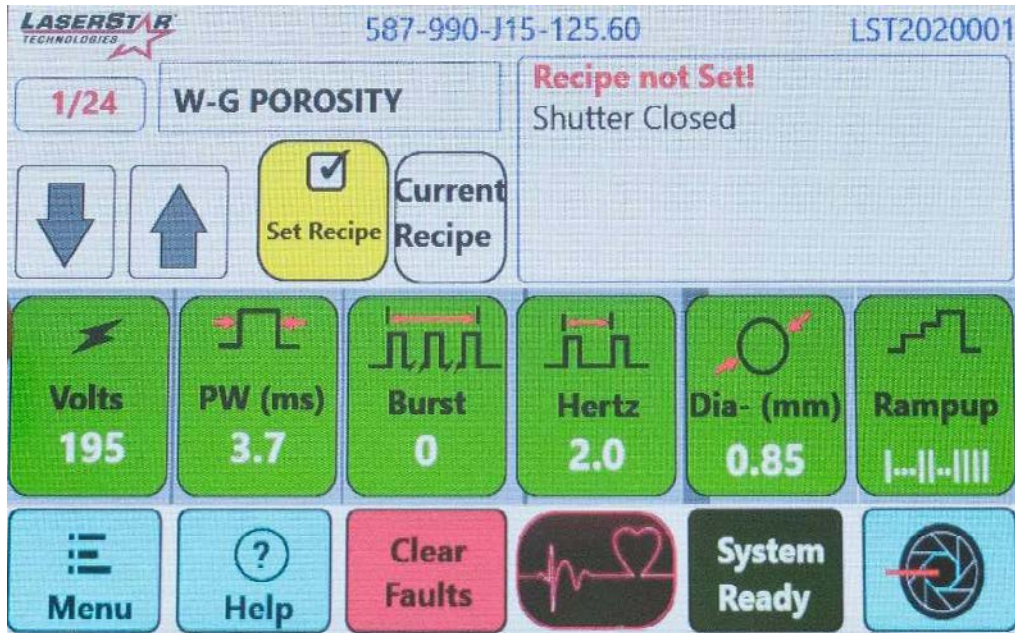
## **Changing the Restricted Mode:**

The restricted access feature is intended to prevent unauthorized changes to the device's welding parameters. This feature is installed prior to shipping.

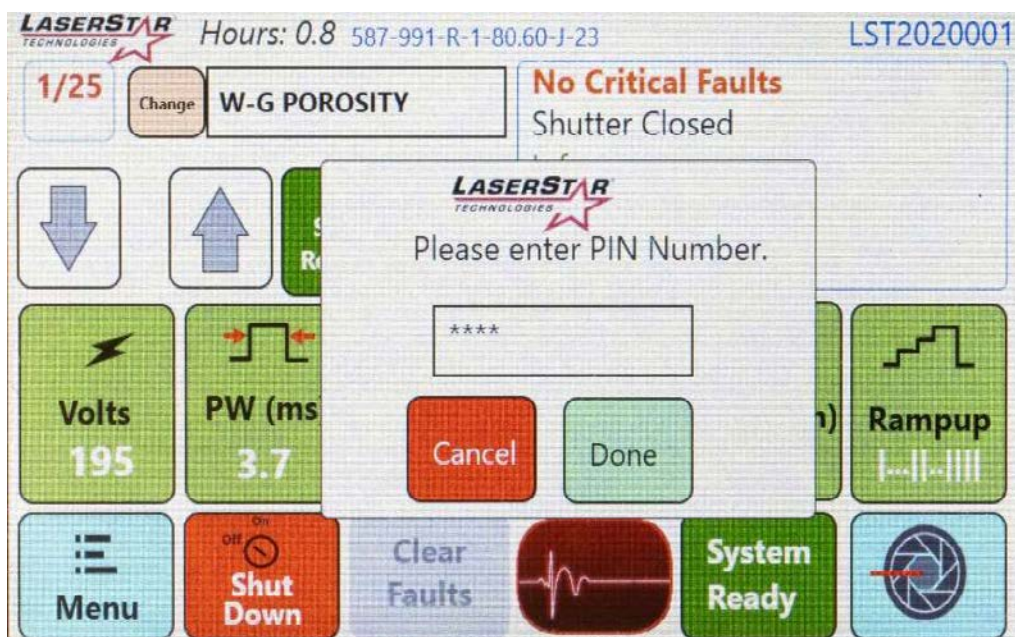
1. Press "MENU" on Main Screen **(Figure 1)**
2. Touch Password (Pin Number) **(Figure 4)**
3. Touch the number box (\*\*\*\*) **(Figure 2)**
4. This will bring up the numerical keypad **(Figure 3)**
5. Type in the default PIN number (9999) or the User PIN number and press the OK button **(Figure 3)**
6. Now press (Done) **(Figure 2)**
7. Press Restricted ON or Off to the desired mode **(Figure 5)**
8. Now press (Done) **(Figure 5)**
9. Press Main Menu Button **(Figure 4)**
10. The Restricted Mode has been set.

**(Note: "Restricted On" disables the parameters/recipes while unchecking "No Password" prevents menu access without the password.)**

## X. Appendix, Section B: Restricted Access & Password (PIN) Protection

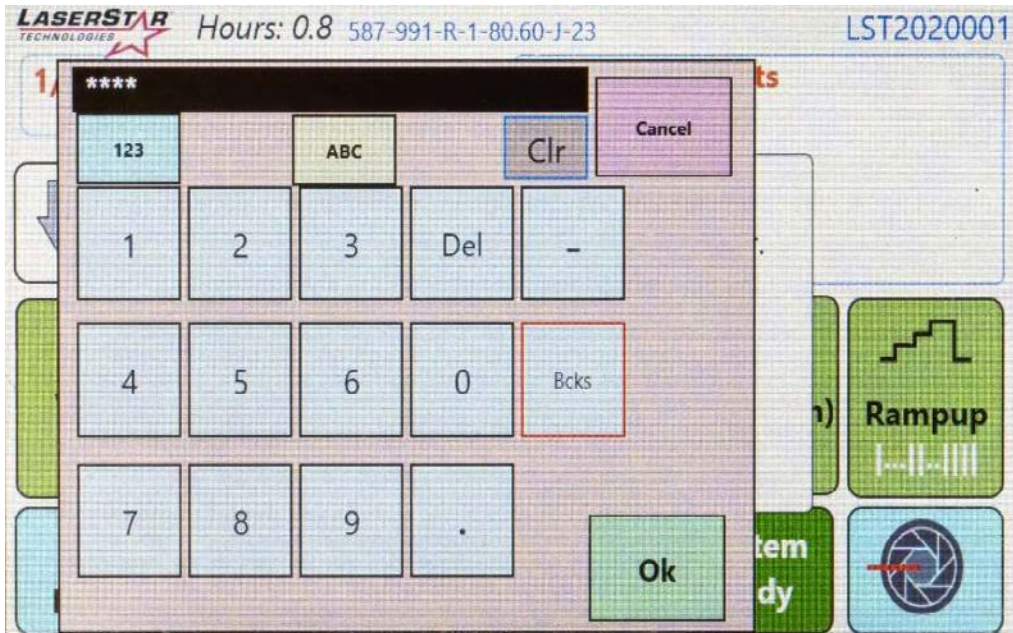


**Figure 1**  
(Main Menu [on-screen])

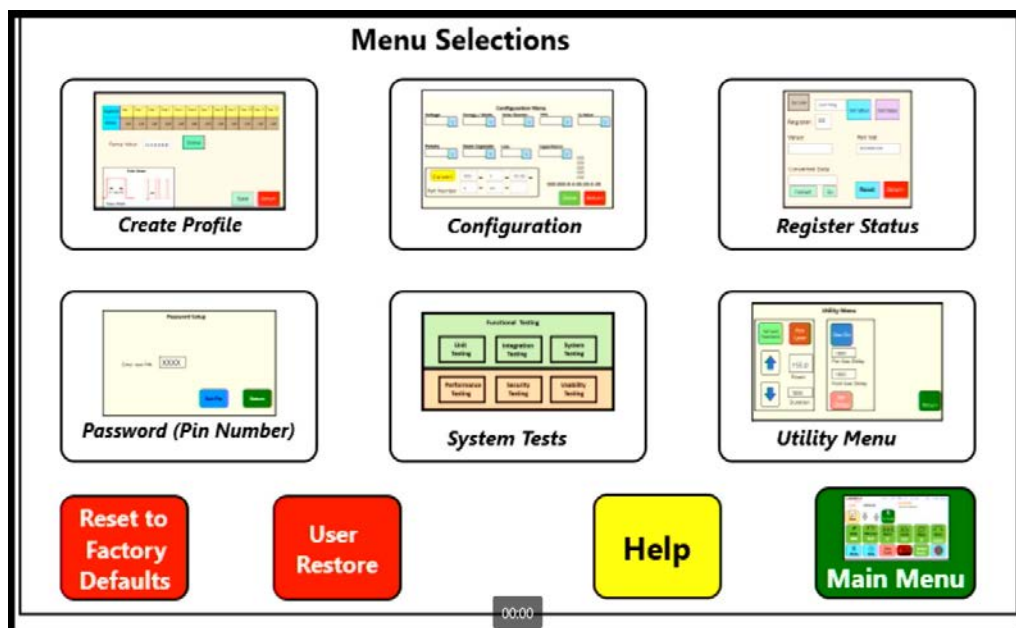


**Figure 2**  
(Input PIN Number [Press Done to Confirm])

## X. Appendix, Section B: Restricted Access & Password (PIN) Protection

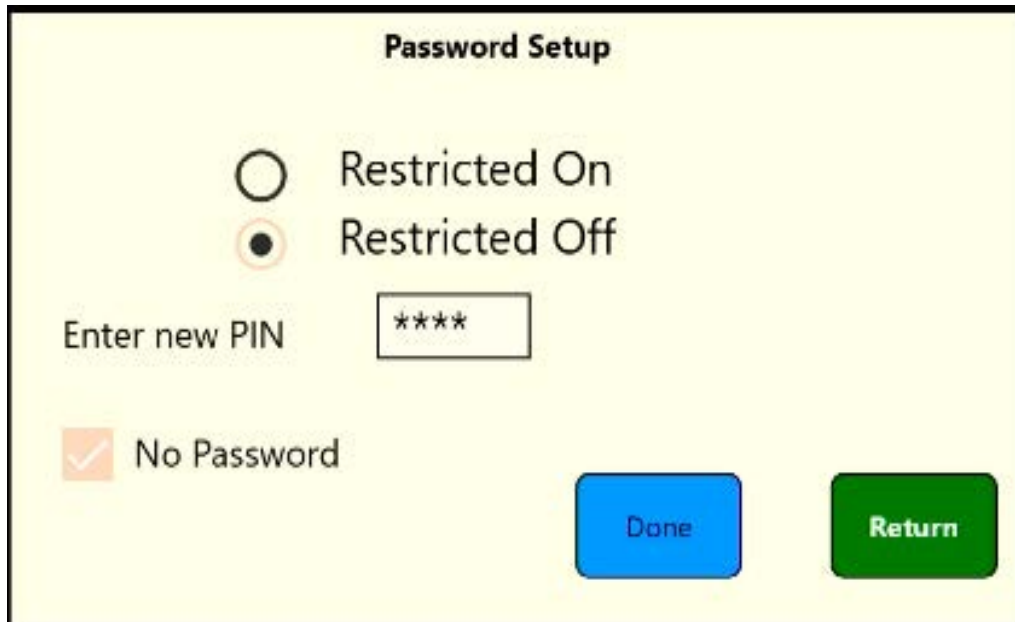


**Figure 3**  
 (Input PIN Number [Enter  
 Value Using Numeric Keypad;  
 Press Ok to Confirm])

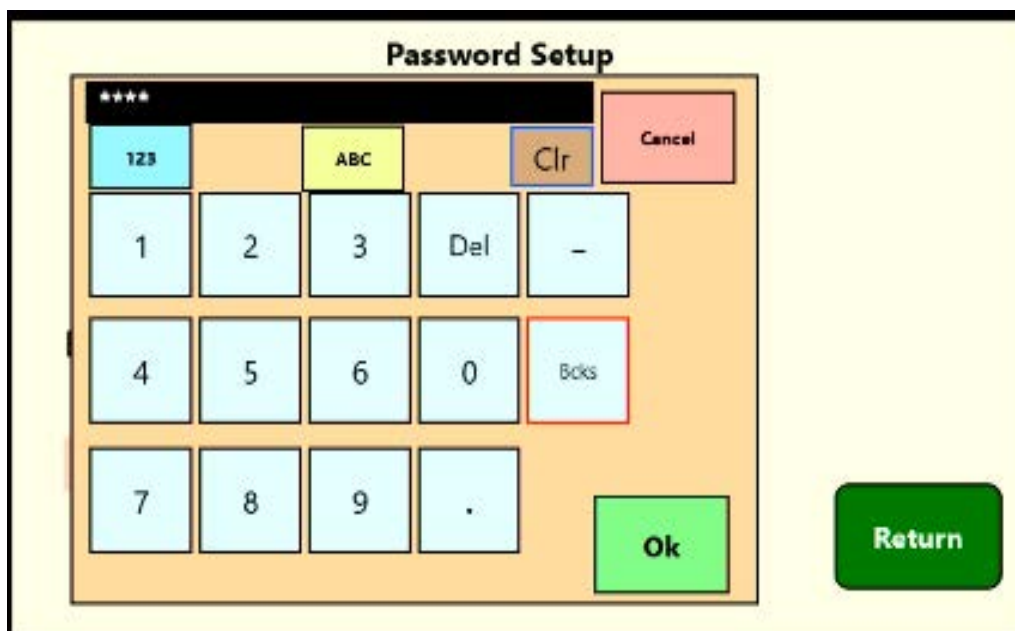


**Figure 4**  
 (LaserStar Service  
 Contacts)

## X. Appendix, Section B: Restricted Access & Password (PIN) Protection



**Figure 5**  
(New Password Setup [Press Done to Confirm])



**Figure 6**  
(New PIN Number [Press Done to Confirm])

## Appendix C: Cleaning, Service, and Maintenance Intervals Chart (with checklist)

The chart on the next page can be used as a resource for tracking cleaning tasks, routine maintenance intervals, and upcoming or anticipated service needs.

### **Important Advisory:**

Routine maintenance is a requirement for ensuring the safe and optimal operation of the welder system. Regular maintenance intervals must be scheduled in accordance with the manufacturer's recommendations and requirements. Use only LaserStar Technologies Corporation® approved parts and accessories. Service personnel must verify the equipment is safe to operate after maintenance is concluded.

<b>LaserStar Technologies: Important Contacts</b>		
<b>Sales &amp; Training</b>	<b>Service &amp; Support</b>	<b>Corporate Office</b>
(407) 248-1142 <a href="mailto:sales@laserstar.net">sales@laserstar.net</a>	1-888-578-7782 <a href="mailto:service@laserstar.net">service@laserstar.net</a>	2461 Orlando Central Pkwy. Orlando, Florida 32809, USA

**Daily: Wipe Laser / Wipe chamber / Clean protective disc** (w) = Water change (w&f) = Water & Filter change

Month 1	Month 2	Month 3	Month 4	Month 5	Month 6	Month 7	Month 8	Month 9	Month 10	Month 11	Month 12
1	1	1	1	1	1	1	1	1	1	1	1
2	2	2	2	2	2	2	2	2	2	2	2
3	3	3	3	3	3	3	3	3	3	3	3
4	4	4	4	4	4	4	4	4	4	4	4
5	5	5	5	5	5	5	5	5	5	5	5
6	6	6	6	6	6	6	6	6	6	6	6
7 Weekly	7 Weekly	7 Weekly	7 Weekly	7 Weekly	7 Weekly	7 Weekly	7 Weekly	7 Weekly	7 Weekly	7 Weekly	7 Weekly
8	8	8	8	8	8	8	8	8	8	8	8
9	9	9	9	9	9	9	9	9	9	9	9
10	10	10	10	10	10	10	10	10	10	10	10
11	11	11	11	11	11	11	11	11	11	11	11
12	12	12	12	12	12	12	12	12	12	12	12
13	13	13	13	13	13	13	13	13	13	13	13
14 Weekly	14 Weekly	14 Weekly	14 Weekly	14 Weekly	14 Weekly	14 Weekly	14 Weekly	14 Weekly	14 Weekly	14 Weekly	14 Weekly
15	15	15	15	15	15	15	15	15	15	15	15
16	16	16	16	16	16	16	16	16	16	16	16
17	17	17	17	17	17	17	17	17	17	17	17
18	18	18	18	18	18	18	18	18	18	18	18
19	19	19	19	19	19	19	19	19	19	19	19
20	20	20	20	20	20	20	20	20	20	20	20
21 Weekly	21 Weekly	21 Weekly	21 Weekly	21 Weekly	21 Weekly	21 Weekly	21 Weekly	21 Weekly	21 Weekly	21 Weekly	21 Weekly
22	22	22	22	22	22	22	22	22	22	22	22
23	23	23	23	23	23	23	23	23	23	23	23
24	24	24	24	24	24	24	24	24	24	24	24
25	25	25	25	25	25	25	25	25	25	25	25
26	26	26	26	26	26	26	26	26	26	26	26
27	27	27	27	27	27	27	27	27	27	27	27
28 Weekly	28 Weekly	28 Weekly	28 Weekly	28 Weekly	28 Weekly	28 Weekly	28 Weekly	28 Weekly	28 Weekly	28 Weekly	28 Weekly
29 Monthly	29 Monthly	29 Monthly	29 Monthly	29 Monthly	29 Monthly	29 Monthly	29 Monthly	29 Monthly	29 Monthly	29 Monthly	29 Monthly
30 Monthly	30 Monthly	30 Monthly	30 Monthly	30 Monthly	30 Monthly	30 Monthly	30 Monthly	30 Monthly	30 Monthly	30 Monthly	30 Monthly
31 Monthly	31 Monthly	31 Monthly	31 Monthly	31 Monthly	31 Monthly	31 Monthly	31 Monthly	31 Monthly	31 Monthly	31 Monthly	31 Monthly
		(w) Change water			(w & f) Change Water & Filter			(w) Change water			(w & f) Change Water & Filter

**Weekly: Check cross-hair alignment / clean & inspect window splash protector**

week 1	week 6	week 11	week 16	week 21	week 26	week 31	week 36 (w)	week 41	week 46	week 51	
week 2	week 7	week 12 (w)	week 17	week 22	week 27	week 32	week 37	week 42	week 47	week 52	
week 3	week 8	week 13	week 18	week 23	week 28	week 33	week 38	week 43	week 48(w & f)		
week 4	week 9	week 14	week 19	week 24(w & f)	week 29	week 34	week 39	week 44	week 49		
week 5	week 10	week 15	week 20	week 25	week 30	week 35	week 40	week 45	week 50		

**Monthly: Clean cabinet, heat exchange / Check water level, replace air & exhaust filters, take Energy Test**

Month 1	Month 2		Month 4	Month 5		Month 7	Month 8		Month 10	Month 11	
Month 3 (w)			Month 6 (w & f)			Month 9 (w)			Month 12 (w & f)		

**(w) Quarterly: Change Water every 3 Months / Change Water & Filter every 6 Months.**

water only - 3rd month						water only - 9th month				
water & filter - 6th month						water & filter - 12th month				GTP 9-23-20

# Appendix D: Pulse Performance Profile (P<sup>3</sup>) Technology

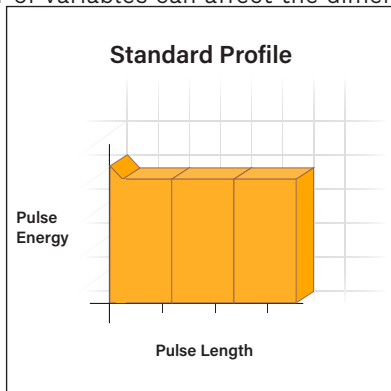
## Background

A pulse of energy from the laser welder consists of a number of characteristics or variables, two of which are pulse power and pulse duration.

The height of a laser pulse is the laser's peak power measured in kW. The pulse can be charted so that the pulse height is shown on the y-axis and the length or duration is shown along the x-axis. The area beneath the curve of the pulse height and pulse length is the pulse energy, which is measured in joules.

The standard pulse shape that is emitted from the laser is a rectangle with an initial spike for the first 1/2 millisecond (1/2 ms) or so. This initial spike (diagram below) helps to break down the reflectivity of the metal, resulting in significantly enhanced energy coupling. This spike can be accentuated or removed altogether, as detailed below.

A number of variables can affect the dimensions and



quality of laser welds. Broadly speaking, welds can be categorized into two (2) "modes:" conduction and keyhole.

With conduction welds, the surface of the metal melts, and through heat conduction, a portion of the metal beneath the laser pulse spot also liquefies. With conduction welds, heat loss through conduction limits the maximum depth of the weld to approximately 1 mm (depending on the material).

Keyhole welds, unlike conduction welds, penetrate much deeper into the surface of the metal, but the process differs. With keyhole welds, in order to cut deeply into the metal material, a channel must be created and some of the material must be vaporized; through the process of either vaporization or splatter, metal material is lost.

### Variables that affect melt pool dimensions and the quality of spot welds include:

- Spatial energy distribution for the incident beam
- Pulse height (peak power)
- Pulse energy (application dependant)
- Pulse length (duration)
- Profile shape

## About Pulse Performance Profile (P<sup>3</sup>) Technology

The process for profiling a laser pulse requires specifying which of 12 segments of the pulse width the laser should be firing for.

To benefit from pulse profiling and achieve noticeable results, a minimum 1.5 millisecond (1.5 ms) pulse duration must be employed.

The energy required for pulsed laser welding can vary, depending upon the application and profile selected. For example, a pulse profile can be chosen for its slower cooling, surface cleaning, bulk heating or even vaporization of contaminants: the energy distribution requirements will differ for each of these applications. When this is the case, the energy required (both voltage and pulse length) will also increase to compensate, ensuring consistent weld penetration, despite the application of a custom profile preset.

### About Pulse Performance Profile (P<sup>3</sup>) Technology Continued on Next Page

## About Pulse Performance Profile (P<sup>3</sup>) Technology (continued)

These parameter adjustments have the potential to reduce lamp life, processing speed, and/or increase cycle times. However, this is a small price to pay and is almost always worth the noticeable improvement in the quality of the weld.

Conversely, if the initial spike is increased to improve energy coupling or duty cycle, **Burst** profiles are used, and the process can become much more efficient (less energy per pulse is used with pulse profiling for the same task).

When in doubt about which pulse profile may be most beneficial, you should first experiment with a **Basic** profile, taking note of the energy used (parameter selections) for a particular application. Next, select a recommended pulse profile and execute the application, again checking the energy used (parameter selections). Finally, compare the results of the two processes and choose a profile that meets your quality and processing speed requirements.

### Getting Started

Normally, a **Basic** profile is entirely appropriate when welding standard ferrous alloys without plating. However, pulse profiling may have a measurable effect on quality and consistency for welding applications with reflective, very dissimilar or contaminated material. For example, small, hairline cracks may be visible in particular alloys when using a **Basic** profile. However, when a **Ramp Down** profile is chosen, a solid, excellent weld is produced.

To determine if Pulse Performance Profile Technology will benefit your applications, it's important to become familiar with the parameter selections process for your machine. Second, you should understand pulse profiles and how adjustments can affect pulse energy output and impact welding materials. Lastly, work toward process improvements by employing a pulse profile. Try a profile based on its description and recommended use, measuring differences in the weld when compared with a **Basic** profile.

If, when you experiment with pulse profiles, you find that penetration is sacrificed, be sure to increase the energy (V) when actual processing is taking place. If the results are worse, try a different pulse profile configuration.

After experimenting with various pulse profiles, don't be concerned if you discover that the **Basic** profile is the best option for your application — at least you've committed to the process of experimentation for the sake of optimization.

### Using P<sup>3</sup> Technology

A variety of pulse profiles have been embedded into the laser's micro-welding software; seven (7) in total. Each profile has been programmed and stored in a specific memory location.

#### The following pulse profiles are preloaded and available for use with the welder:

- Basic
- Spike
- Ramp Down
- Ramp Up
- Pyramid
- Pre-pulse
- Burst

All pulse profiles are voltage proportional. For each profile, if the voltage increases, the energy per section also increases; the energy output percentage will, however, always remain the same.

The energy per section is proportional to the selected pulse length. To activate the pulse profile, a minimum pulse length of 1.5 milliseconds (1.5 ms) is required.

As an example, when the pulse length is 1.5 milliseconds (1.5 ms), each section's pulse width will be 0.125 milliseconds (0.125 ms). If the pulse length is 6 milliseconds (6 ms), each section's pulse width will be 6 milliseconds (6 ms) divided by 12, which equals 0.5 milliseconds (0.5 ms), and so on.

**Pulse Profiles, Voltage, and Energy Continued on Next Page**

## Using P<sup>3</sup> Technology (continued)

All pulse profiles (with exception of **Basic**) have a minimum pulse length of 1.5 milliseconds (1.5 ms). If a shorter pulse length is selected, the parameter will automatically reset to the default setting.

<b>Pulse Profiles: Technical Specifications</b>				
<b>Imbedded Pulse Profiles (quantity)</b>	<b>Pulse Width</b>	<b>Energy Levels (per section)</b>	<b>Energy Sections (quantity)</b>	<b>Section Pulse Width (minimum value)</b>
7	1.5 ms	2 (0%, 100%)	12	0.125 ms

<b>Pre-programmed Pulse Performance Values</b>		
<b>Shape</b>	<b>Average Energy per 1/3 Segment</b>	<b>Profile Settings</b>
<b>Basic</b>	100%, 100%, 100%	1111 1111 1111
<b>Spike</b>	100%, 25%, 25%	1111 0001 0001
<b>Ramp Up</b>	25%, 50%, 100%	1111 0011 0001
<b>Ramp Down</b>	100%, 50%, 25%	1000 1100 1111
<b>Pyramid</b>	50%, 100%, 50%	1100 1111 1100
<b>Pre-pulse</b>	50%, 100%, 75%	1100 1111 1110
<b>Burst</b>	50%, 50%, 50%	1100 1100 1100

## Switching Pulse Profiles

**There are two (2) methods for changing the Pulse Profile:**

**1. Touchscreen:**

- a. Select the **Pulse Profile** from the **main menu** parameters.
- b. Press the **Up** or **Down Arrows** to scroll through the various Pulse Profiles.
- c. When the desired profile is displayed, select “Done”.

**2. Joystick (in-chamber):**

- a. Move the **joystick** to the right twice to select the Pulse Profiles.
- b. Move the joystick up or down to scroll through the various Pulse Profiles.
- c. When the desired profile appears on the display, either hit the foot pedal or wait 2 seconds.

## Pulse Profiles: Custom Profile

Some applications may require a specialized Pulse Profile with a different energy distribution than the standard 7 profiles. The steps below detail the process to create a custom Pulse Profile.

**To change the power level, do the following:**

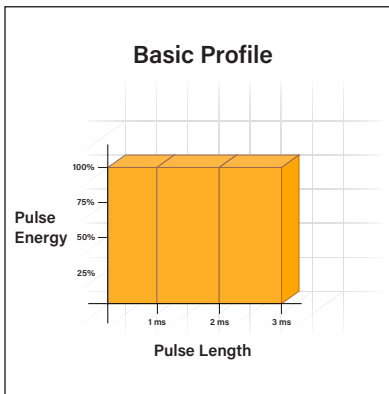
1. Press the **“Menu” icon** on the main menu.
2. Select the **“Create Profile” icon** in the upper left corner of the screen.
3. Press on any of the twelve pulse segments to turn the laser beam off for that segment.
4. Once the Pulse Profile is complete, hit **“Done.”**
5. Tap on the text box in the new window to assign a name to the Pulse Profile, then hit **“Save.”**
6. Hit **“Return”** to return to the menu.
7. Hit **“Main Menu”** to return to the main menu and weld parameters screen.

**To delete a custom Pulse Profile, simply select the pulse profile with the touchscreen and select the “Delete” icon.**

## Basic Profile (yellow gold, platinum, and stainless steel)

For very low penetration welds that require excellent cosmetic presentation or when welding volatile materials, such as low melting point alloys, a **Basic** profile, which suppresses the initial higher peak power spike, can be beneficial.

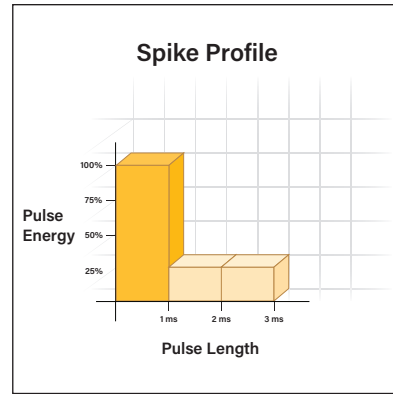
By eliminating the spike, the weld puddle will vibrate less during cooling. Ripples on the melt surface caused by vibration freeze within the puddle, producing a more rigid and less shiny surface. Materials with a low melting point or those with better absorption will not require an initial spike.



## Spike Profile (silver and copper; with silver [use tacking or single-pulse mode])

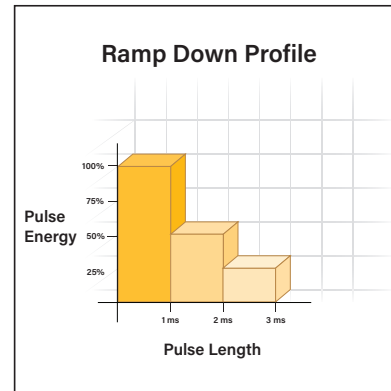
A **Spike** profile is helpful for highly reflective metals with higher conductivity, such as pure copper alloys, silver alloys, and some aluminum alloys or for applications in which the surface is highly reflective and the focused spot is larger.

With this profile, the initial spike in the first section is produced and initiates melting of the material surface. Next, absorption increases (by up to 20 times), ensuring that the remainder of energy from the laser pulse can be lowered. This can reduce the overall energy required, making coupling much more consistent and reducing weld spatter from the process (see diagram at top right).



## Ramp Down Profile (silver and aluminum)

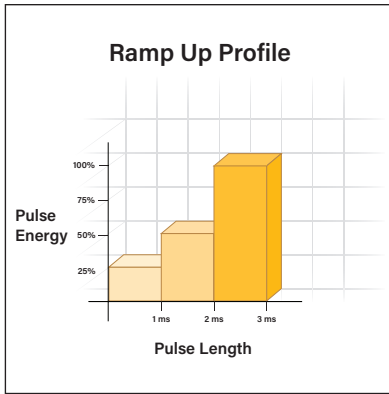
With higher carbon steels, alloys that are prone to cracks, casting alloys with voids or contaminants (or when the materials to be welded have very dissimilar melting points) a **Ramp Down** profile can be a huge benefit in the reduction of cracks and porosity (voids) in the weld.



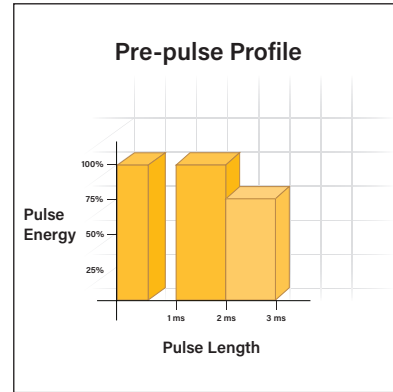
## Ramp Up Profile (white gold)

When welding materials with low melting points and with very low reflectivity or when welding materials with many volatile contaminants or with plating, the **Ramp Up** profile is helpful (see diagram on next page).

Pulse Profile Applications and Usage Continued on Next Page

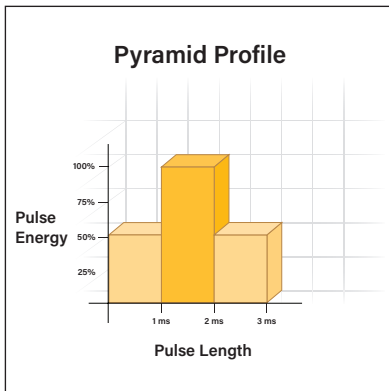


that it eliminates all contaminants. Usually, a delay of up to 1/2 millisecond (1 ms) follows to allow the material to get out of the weld zone. Then, the main weld process occurs, striking a consistent surface to ensure creation of a quality weld.



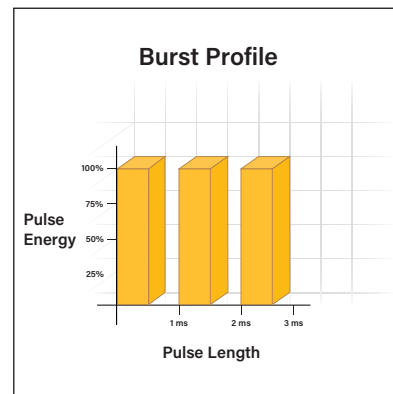
### Pyramid Profile (titanium)

Combines characteristics from both the **Ramp Up** and **Ramp Down** profiles and is suitable for welding dissimilar metals that are non-reactive to oxygen.



### Burst Profile (pewter, hollow [thin wall], and low-melting pot metal)

Essentially, the **Burst** profile delivers pulse energy output in repeated cycles with a consistent peak power. It has been shown to have value and a positive effect, increasing the overall weld depth.

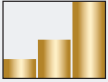

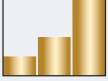


### Pre-pulse Profile (eyeglasses)

When welding materials that have a low melting or boiling point, a plating or surface covering, or those that contain contaminants, such as pre-tinned electronic parts, anodized parts, painted parts or oil-contaminated parts, a **Pre-pulse** profile is helpful. Additionally, parts that have varying reflectivity, due to coating differences, oxidation or surface finish can benefit from a **Pre-pulse** profile.

This profile has an initial section with enough energy to vaporize and/or partially weld materials while also ensuring the heat penetrates the material enough


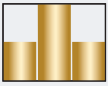

## Recommended Pre-programmed Parameter Settings

<b>Metal Type</b>	<b>Parameter</b>	<b>Voltage</b>	<b>Pulse Profile</b>
White Gold 	Porosity	195V 3.7ms 2.0Hz 0.85mm	<b>Ramp Up</b>
White Gold 	Re-tip	195V 3.5ms 2.0Hz 0.65mm	<b>Ramp Up</b>
White Gold 	Size Thin	208V 3.5ms 2.0Hz 0.70mm	<b>Ramp Up</b>
White Gold 	Size Thick	210V 7.0ms 2.0Hz 0.60mm	<b>Ramp Up</b>
Yellow Gold 	Porosity	195V 3.0ms 2.0Hz 0.70mm	<b>Basic</b>
Yellow Gold 	Re-tip	176V 3.0ms 2.0Hz 0.60mm	<b>Basic</b>
Yellow Gold 	Size Thin	203V 3.4ms 2.0HZ 0.60mm	<b>Basic</b>
Yellow Gold 	Size Thick	275V 4.0ms 2.0HZ 0.70mm	<b>Basic</b>
Silver 	Porosity	230V 3.5ms 2.0HZ 0.70mm	<b>Ramp Down</b>
Silver 	Re-tip	235V 3.5ms 2.0HZ 0.75mm	<b>Ramp Down</b>
Silver 	Size Thin	255V 4.5ms 2.0HZ 0.75mm	<b>Ramp Down</b>

**(Note: The parameter combinations above and in the table that follows are suggested starting points and are subject to change based on flashlamp age and alloy surface.)**

**Recommended Pre-programmed  
Parameter Settings Continued on Next Page**

## Recommended Pre-programmed Parameter Settings

<b>Metal Type</b>	<b>Parameter</b>	<b>Voltage</b>	<b>Pulse Profile</b>
Silver 	Size Thick	290V 6.0ms 1.5Hz 0.65mm	<b>Ramp Down</b>
Platinum 	Porosity	220V 3.0ms 2.0Hz 0.70mm	<b>Basic</b>
Platinum 	Re-tip	220V 3.0ms 2.0Hz 0.80mm	<b>Basic</b>
Platinum 	Size Thin	225V 3.0ms 2.0Hz 0.60mm	<b>Basic</b>
Platinum 	Size Thick	250V 6.0ms 2.0Hz 0.75mm	<b>Basic</b>
Jump Rings 		213V 2.3ms 2.0Hz 0.75mm	<b>Basic</b>
Titanium 		211V 3.0ms 2.0Hz 0.65mm	<b>Pyramid</b>
Hollow 		194V 3.0ms 8.0Hz 0.45mm	<b>Burst</b>
Pewter 		180V 3.0ms 8.0Hz 0.60mm	<b>Burst</b>
Base Metal (white) 		195V 3.5ms 7.0Hz 0.80mm	<b>Burst</b>
Eyeglasses 		195V 3.5ms 2.0Hz 0.75mm	<b>Pre-pulse</b>
Stainless Steel 		200V 2.8ms 3.0Hz 0.70mm	<b>Basic</b>
Cross-hair Align 		200V 3.0ms 0.0Hz 0.70mm	<b>Basic</b>

**If you have additional questions about your machine or would like to provide feedback, a testimonial or present your applications results, please reach out — we'd love to hear from you!**

<b>LaserStar Technologies: Important Contacts</b>		
<b>Sales &amp; Training</b>	<b>Service &amp; Support</b>	<b>Corporate Office</b>
(407) 248-1142 <a href="mailto:sales@laserstar.net">sales@laserstar.net</a>	1-888-578-7782 <a href="mailto:service@laserstar.net">service@laserstar.net</a>	2461 Orlando Central Pkwy. Orlando, Florida 32809, USA

The background features a dark blue gradient on the left and a white area with diagonal lines on the right. A horizontal band of digital data, represented by vertical blue lines of varying heights and widths, spans across the middle. Below this band, there are several overlapping geometric shapes in shades of blue and white, creating a layered, modern aesthetic.

**For additional resources, learning, and support,  
including our library of latest video how-tos,  
be sure to visit us online:**

[LaserStarAcademy.com](http://LaserStarAcademy.com), [LaserStar.net](http://LaserStar.net), and [LaserStar.TV](http://LaserStar.TV)